

User Manual

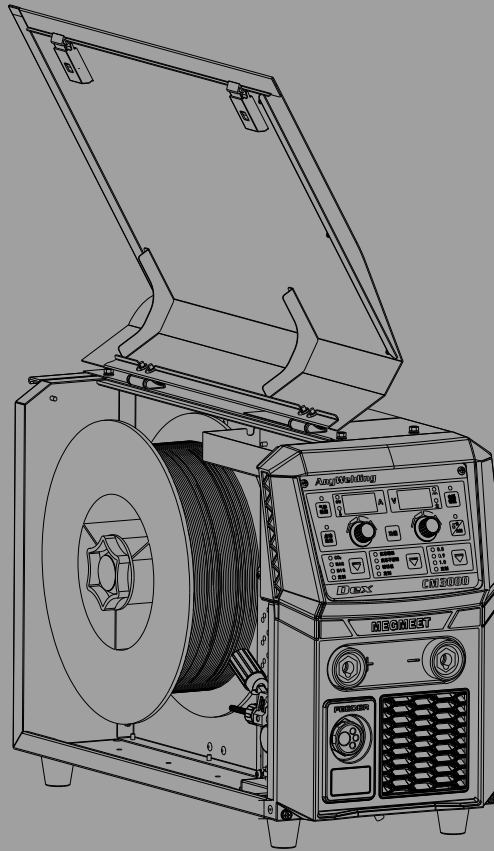

Dex Fully-digital Converter CO₂/MAG/MIG Multi-function Welding Power Source

Dex CM3000

Dex PM3000

MEGMEET

Full-Digital Control CO₂/MAG/MIG Multi-FunctionWelding Machine

User Manual

Model: Dex CM/PM 3000

Version: V1.0

Code : R33010360

Shenzhen Megmeet Electric Co., Ltd(Megmeet) provides customers with all-around technical supports, including but not limited to opening CAN communications, welding process database software upgrading, and after-sales service etc. Users can contact a nearby representative office or Customer Service Center of Megmeet, or directly contact Megmeet Headquarter.

All rights reserved by Shenzhen Megmeet Electric Co., Ltd.
The contents are subject to change without further notice.

Shenzhen Megmeet Electric Co., Ltd.

Address: 5thFloor,Block B Unisplendour Information Harbor,LangshanRoad,shenzhen,518057,China

Website: www.megmeet.com

Customer servicehotline:4006662163

E-mail:Welder.4S@megmeet.com

Preface

Thank you for choosing the full-digital inverter CO₂/MAG/MIG multi-function welding power source manufactured by Megmeet (hereinafter referred to as “welder”). This manual presents precautions on installation and wire connection, parameters setting, troubleshooting and daily maintenance.

Please read this User Manual carefully before installation to ensure correct installation and operation of the welder. Please keep it properly and deliver to the user.

Megmeet will consistently carry out product development and innovation. If the actual product is not in conformity with the content, parameters, or diagrams in this document, the actual product shall prevail. This document may subject to change without notice and Megmeet reserves the right of final interpretation of this document.

Safety precautions

Safety Definition

In order to use the welding power source safely and correctly to prevent harm to you or others and other damages, this manual uses various types of warning labels. Please be sure to follow the instructions carefully.

The following signs are classified according to the degree of danger or damage:



Please follow the instructions, otherwise it may cause death or serious injury.

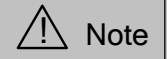

Please follow the instructions, otherwise it may cause moderate or minor injuries or damage to property.

- Before handling the welder, the input power supply of distribution box should be cut off.
- Make sure that the machine casing has been firmly installed before handling of the welder.
- Please install it on a noncombustible object, otherwise it may lead to fire hazard.
- Do not put any combustible material around the welder, otherwise it may lead to fire hazard.
- Do not install it in an environment containing explosive gas, otherwise it may lead to explosion hazard.
- Wiring operation should be performed by professional qualified personnel, otherwise it may lead to electric shock hazard.
- Do not do wiring until confirming that the input power has been fully disconnected, otherwise it may lead to electric shock hazard.
- The machine casing should be covered up before power on, otherwise it may lead to electric shock hazard.
- Do not touch the terminal with hands when the machine is powered on, otherwise it may lead to electric shock hazard.
- Do not operate the welder with wet hands, otherwise it may lead to electric shock hazard.

Installation Precautions



DANGER

- Wiring operation should be performed by professional qualified personnel, otherwise it may lead to electric shock hazard.
- Do not do wiring until confirming that the input power has been fully disconnected, otherwise it may lead to electric shock hazard.
- The machine casing should be covered up before power on, otherwise it may lead to electric shock hazard.
- Do not touch the terminal with hands when the machine is powered on, otherwise it may lead to electric shock hazard.
- Do not operate the welder with wet hands, otherwise it may lead to electric shock hazard.
- Part replacement should be performed by professional personnel. It is forbidden to leave the wire head or metal objects in the machine, otherwise it may lead to fire hazard.
- After replacing the control panel, the parameters must be set correctly before running, otherwise it may cause damage to property.
- Use the exposed part of the cable nose for wiring. Wrap it up with insulating tape, otherwise it may lead to

electric shock hazard.

- Maintenance operation can only be carried out 5 minutes after disconnecting the power supply. At this time, the welding power indicator light will be completely extinguished. Confirm that the positive and negative bus voltage should be under 36V, otherwise it may lead to electric shock hazard.
- It is prohibited to open the side cover of the machine by hand while storing or using the machine outdoors on rainy days.

ATTENTION

- Avoid the operation panel from falling off during handling process, otherwise it may lead to the risk of injury or damage to property.
- Fix the wheels firmly while handling the welder with a forklift truck.
- The welding machines should be installed at a place which can support its weight, otherwise it may lead to the risk of injury or damage to property if it falls off.
- It is strictly forbidden to install the machine at a place with water pipes or others which may produce water splashing; otherwise it may cause damage to property.
- Don't put screws, gaskets and metal bars into the welder, otherwise it may lead to fire hazard or damage to property.
- If the welding machine is damaged or the components are not complete, the machine should not be installed and used, otherwise it may lead to fire hazard or damage.

The quick plug of the main circuit terminal should be rotated to connect tightly, otherwise it may lead to damage to property.

Safety Precautions

DANGER

- In order to ensure safety, welding operation should be performed by personnel with safe operation knowledge and welding skills.
- Please do not use welding machine for the purposes other than welding.
- Installation, commissioning and maintenance of welding machine must be carried out by professionals.
- Operators who use a cardiac pacemaker shall not get close to the welder and welding operation site without the permission of doctor.
- Do not touch live parts, otherwise it may lead to electric shock hazard.
- Do not use cable with insufficient section area, exposed conductor or any damage.
- Do not demount the shell while using the machine.
- Please use intact insulating gloves with excellent insulating property.
- Please take safety measures for high altitude operation.
- Please turn off the power of welding machine and distribution box when it is not in use.
- When weld in a narrow or confined space, please accept the supervision from inspectors and ensure sufficient

ventilation or use breathing apparatus; otherwise, the operator may get asphyxiated due to lack of oxygen.

- Welding process will produce harmful fumes and gases. Therefore, please ensure adequate ventilation or use breathing apparatus, otherwise, it will endanger your health.
- Please do not weld pressure vessels such as pipes filled with gas or sealed tank.
- Please do not keep thermal parts close to combustible materials.
- Please do not weld around combustible materials.
- Please put fire extinguishers around welding operation place.
- Fix the gas cylinder with special brackets, otherwise the gas cylinder may topple over which will lead to personal injury.
- Please do not make the electrode contact the gas cylinder.
- Please correctly use pressure-relief valve as required.
- Disassembly and maintenance of pressure reducing valve should be performed by professionals.
- Please do not contact the fan, wire feeding machine and other rotating parts, otherwise it may cause personal injury.
- While performing welding or supervising welding, please use protective equipment with sufficient shading performance to prevent the arc from damaging eyes or skin.
- Please use leather protective gloves for welding, long-sleeved clothes, welding spats, apron, glasses and other protective equipment to prevent damage caused by arc, splash and welding slag etc.
- Set protective barriers around the welding site to prevent the arc from hurting others.
- Please use sound insulation instruments to prevent noise hazard.

ATTENTION

- It is forbidden to use this welding machine on operations other than welding.
- Please do not place heavy objects on the welder.
- Please do not block the ventilation opening of welding machine.
- Please place it in a place where spatter and other metal objects will not fall inside the welder.
- Please keep the machine more than 30cm away from wall or other welders.
- To prevent the wind from blowing the arc directly, please use a screen for shielding.
- Please fix the wheels and avoid welding machine sliding.
- In order to prevent electromagnetic hazard, perform electromagnetic shielding for cable and welding operation site.
- The inclination angle of welding machine installation plane should be less than 15° to prevent toppling of machine.
- Protection grade of welding machines IP23S. The operation environment requirements are as follows:
- Operating temperature range: $-10^{\circ}\text{C} \sim +40^{\circ}\text{C}$;

Transportation and storage temperature range: $-40^{\circ}\text{C} \sim +70^{\circ}\text{C}$

Operating humidity range: Not exceed 75%RH at 40°C ; not exceed 95%RH at 20°C .

Altitude shall not be higher than 2,000m.

Operating environment should be free of obvious mechanical vibration or mechanical shock.

Inclination angle of welder shall not be more than 15 °.

Dust, metal dust and corrosive gases in ambient air shall not exceed the normal content

Avoid the welding machine exposed to rain or rainwater invasion to fan.

Precautions for Scrapping

Please note at welding machine scrapping that:

- An explosion may occur during incineration of the electrolytic capacitor on the main circuit and PCB.
- Plastic parts such as front panel will generate toxic fumes during incineration.
- Please handle the scrapped machine as industrial waste.

Contents

Chapter I Product Overview	1
1.1 Brief Introduction	1
1.2 System Composition	1
Chapter II Wiring Installation	2
2.1 Unpacking	2
2.2 Installation Requirements.....	2
2.3 Precautions for Handling.....	2
2.4 Serial Number of Machine	2
2.5 Machine Installation and Electrical Connection.....	2
2.5.1 380VAC Power Input Cable.....	3
2.5.2 Welding Torch Connection	3
2.5.3 Welding Cable (Ground Wire) Connection beside the Workpiece.....	3
2.5.4 Wire Feeding Roller Installation	4
2.5.5 Wire Spool Installation	5
2.5.6 Regulation on Pressure Adjusting Rod.....	5
2.5.7 Air Supply System Connection.....	5
Chapter III Dex CM3000 Function Description and Operation	6
3.1 Front Panel	6
3.2 Buttons and Knobs.....	6
3.3 Wire Inching.....	6
3.4 Gas Detection	6
3.5 Synergic/Separate	7
3.6 Arc Dynamics.....	7
3.7 Internal Menu	8
Chapter IV Dex PM3000 Function Description and Operation	17
4.1 Front Panel	17
4.2 Wire Inching.....	18
4.3 Gas Detection	18
4.4 Synergic /Separation	18
4.5 Arc Dynamics.....	19
4.6 Arc Starting Parameter.....	19
4.7 Arc Ending Parameter.....	20
4.8 Welding Control	20
4.9 Storage and Invocation.....	23
4.10 Internal Menu	23
Chapter V Troubleshooting	33
5.1 Welding Machine Fault Indication	33
5.2 Fault Codes and Solutions.....	33
Chapter VI Maintenance	35
6.1 Daily Inspection.....	35
6.2 Periodic Inspection	36
6.3 After-Sales Services.....	37
Annex I Technical Specifications	38
Annex II Electrical Connection Diagram	39
Annex III System Configuration Table	40
Annex IV Structural Detail Drawing	42

Chapter I Product Overview

1.1 Brief Introduction

Dex CM3000 and Dex PM3000 is a full digital control multi-functional integrated welding machine, It applies to welding of car seats, motorcycles, sheet metal and medium thin plates, as well as backing (root welding)weld of medium thick plates, etc.

- With the functions of , MAG, MIG gas shielded welding and manual arc welding.
- Special welding control method can be customized for customers.
- Three-electrical level technique with an inverting frequency up to 180KHz is adopted.
- Dex CM3000 can be used for welding with a variety of welding materials including carbon steel, stainless steel, and galvanized sheet etc.
- Dex PM3000 can be used for welding for carbon steel, stainless steel , pure aluminum ,aluminum and other welding materials.

1.2 System Composition

Welding machine system is as shown in Fig. 1-1.

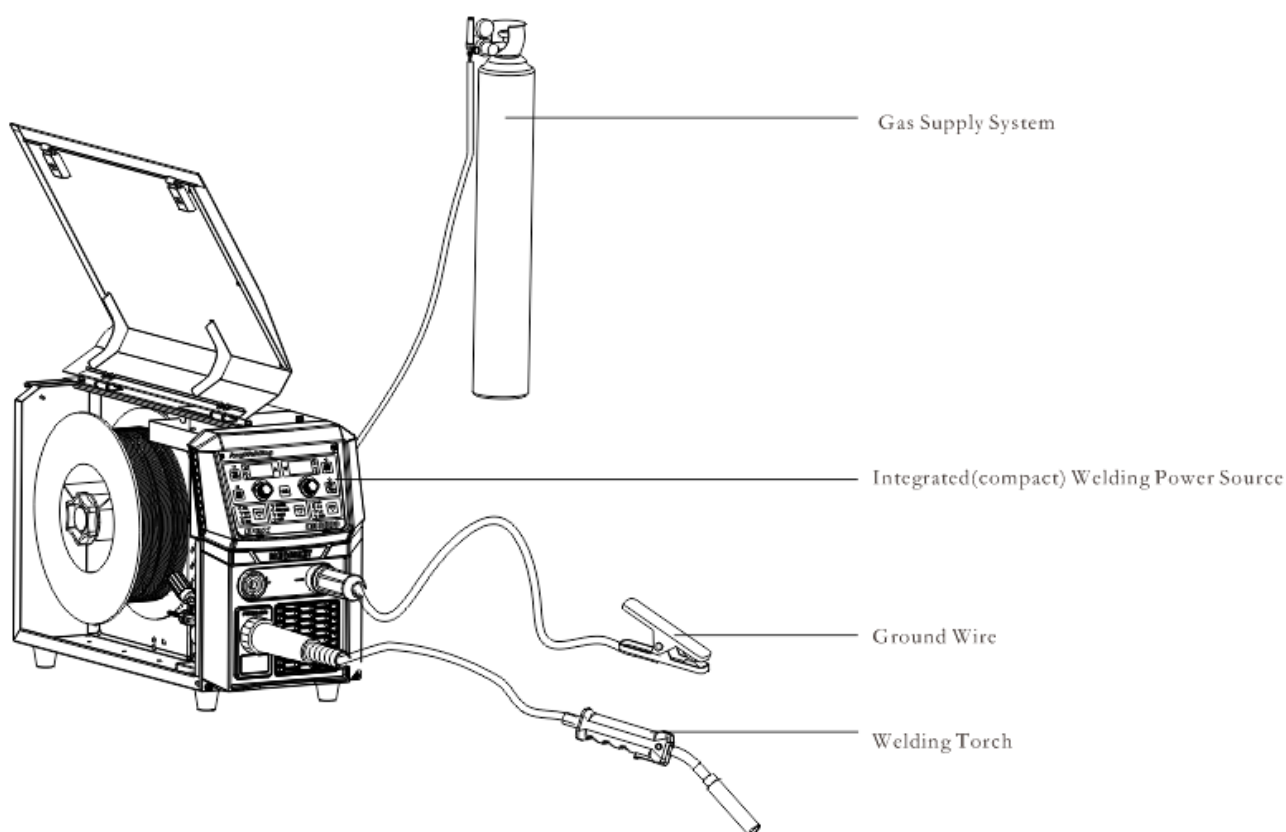

Fig. 1- 1System Composition

Chapter II Wiring Installation

The chapter presented the installation requirements of welding machine, as well as the operation steps and precautions associated with the installation.

2.1 Unpacking

The machine is packed with a specially designed & durable package.

1. Please confirm whether the outer package of the product is intact.
2. After unpacking, please confirm whether the welder accessories, installation and operating instructions are intact and whether the model is consistent with the order.
3. Packaging materials can be recycled.

2.2 Installation Requirements

Environmental requirements

The following items should be noted while selecting the installation environment:

1. It should be installed at a place with good ventilation and the vibration should be less than 5.9 m/s (0.6 g).
2. Avoid installing the machine at a place with much dust and metal powder.
3. It is strictly prohibited to install the machine at a place with corrosive or explosive gas.
4. The environment temperature should be within the range of $-10^{\circ}\text{C} \sim +40^{\circ}\text{C}$. When the temperature exceeds 40°C , external forced cooling or derating use is required.
5. The humidity should be lower than 95%, and should be free of water condensation. Pay attention to wind prevention at the welding site.
6. Use a windshield or else if necessary, otherwise the welding process will be affected.
7. Prevent the machine from exposure to rain and direct sunlight.
8. Please consult and confirm in advance if there are any special installation requirements.
9. Installation space requirements: It is recommended to place the welding power according to the reserved space as specified in Table 2-1.

Table 2-1 Reserved Space for Installation of Welding Power

	Front	Top	Left	Right	Back
Reserved space	$\geq 20\text{cm}$	$\geq 40\text{cm}$	$\geq 60\text{cm}$	$\geq 20\text{cm}$	$\geq 20\text{cm}$

2.3 Precautions for Handling

Before handling the welding power supply, make sure to cut off the input power of the distribution box and remove the wire inside the welder.

2.4 Serial Number of Machine

The serial number of the machine is unique and is marked on the nameplate. It is very important information for maintenance and spare parts ordering.

2.5 Machine Installation and Electrical Connection

Safety warning

1. Wiring connection should be performed by qualified and professional electrical operator.
2. Electrical connection should be carried on when the distribution box switch is disconnected and safety can be ensured.

3. Please use specified cable.
4. Do not touch the machine with wet hands.
5. Please do not put heavy objects on the cable.
6. Tap-water pipe and the building body steel bar may not be fully grounded. Please do not use it to connect the safety ground wire.
7. Please connect this welding power source with the matching or specified welding gun and gas meter, otherwise it will affect welding performance and welding quality.
8. Install a leakage protector when the workplace is wet and operating on iron plates or iron frames.

2.5.1 380VAC Power Input Cable

This welder is equipped with 3M power supply cable (plug excluded). Please arrange a professional electrician to connect the input cable of the other end to the output terminal of the distribution box switch. The selection of AC input cable shall strictly follow Annex I Technical Specifications.

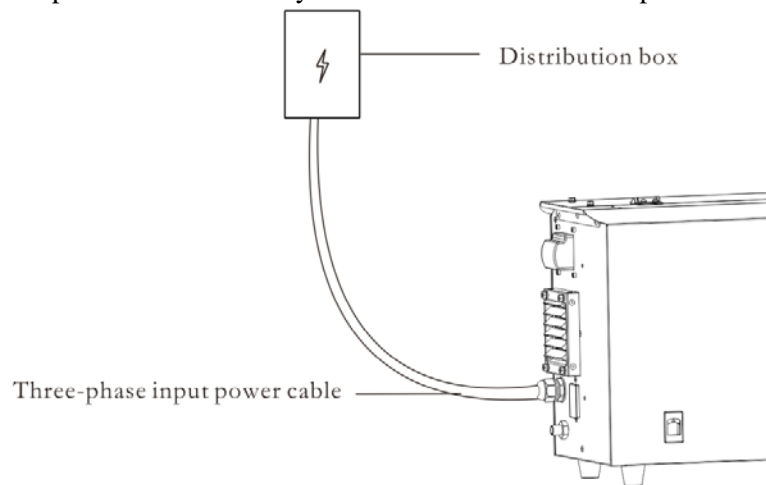

Fig.2- 1380VAC Power Input Side Schematic Diagram

2.5.2 Welding Torch Connection

Align and insert the welding torch to the socket and tighten with clockwise as shown in Fig. 2-2.

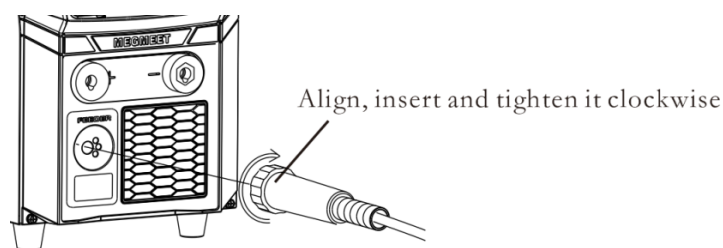

Fig.2- 2 Welding Torch Connection Schematic Diagram

2.5.3 Welding Cable (Ground Wire) Connection beside the Work-piece

Align and insert the ground cable to the socket and tighten it clockwise, as shown in Fig. 2-3. Fasten the other end to the work-piece. Keep the contact area on the work-piece as large as possible. The work-piece surface should be no dirt or painting; otherwise the wire clamp will be burnt.

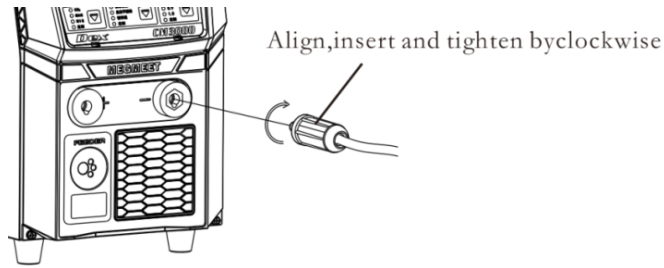

Fig.2- 3Ground Cable Connection Schematic Diagram

Attention

In order to ensure the welding performance and using life of the ground wire, it is suggested that the cross section of the ground wire should be above 25mm².

2.5.4 Wire Feeding Roller Installation

- **Dex CM3000**

Remove the black plastic knob from wire feed roller by counter-clockwise direction. Install the wire-feeding roller according to operation requirements. After wire feeding roller installation, tighten black plastic knob by clockwise. Wire diameter is marked on the wire feed roller. The marked wire diameter is corresponding slot diameter of wire feeding roller.

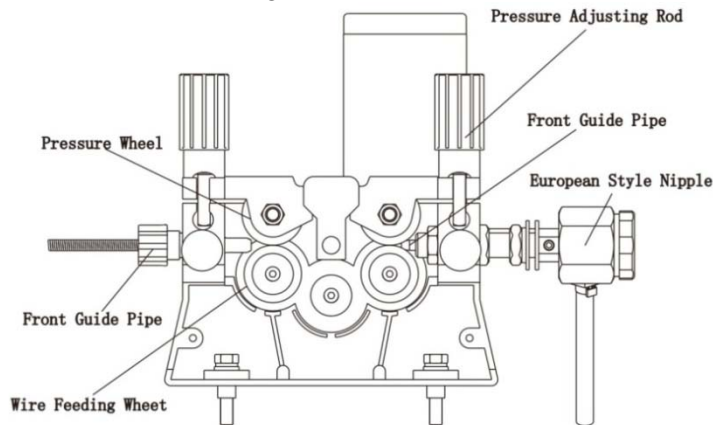

Fig.2- 4Dex CM3000 Schematic Diagram of Wire Driving Motor

- **Dex PM3000**

Remove the screw from wire feeding roller by counter-clockwise direction. Install the wire-feeding roller according to operation requirements. After wire feeding roller installation, tighten the screw by clockwise. Wire diameter is marked on the wire feed roller. The marked wire diameter is corresponding slot diameter of wire feeding roller.

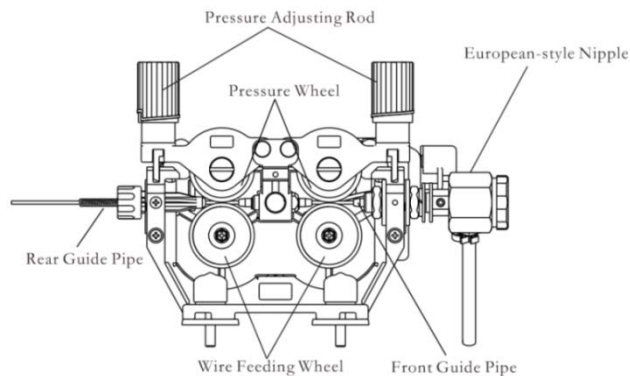
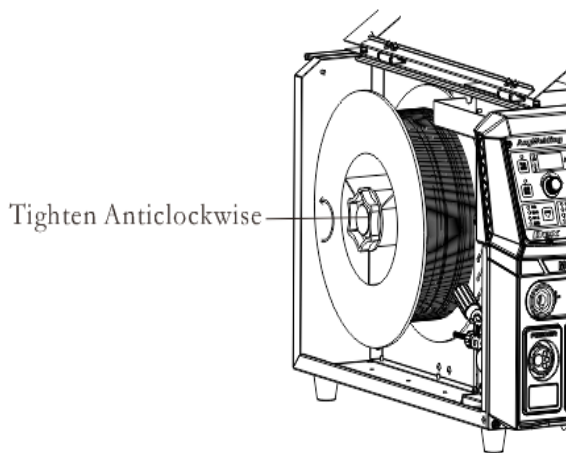

Fig.2- 5Dex PM3000 Schematic Diagram of Wire Driving Motor

2.5.5 Wire Spool Installation



1. Rotate the end cover of the coil shaft by clockwise direction to loosen the end cover.
2. Push in the wire coil; Align the slot of wire coil so that the slot can successfully enter the terminal of disc shaft. In addition, pay attention to the rotation direction of wire coil to avoid reverse direction of wire feeding.
3. Rotate shaft end cover by anti- clockwise, and lock the wire feeding coil.
4. Select and install the suitable wire feed rollers.
5. Extract the wire head from the wire coil, cut off the bending part. The cut welding wire could not fall into the machine. Straighten the welding wire about 20cm and check whether there are any sharp corners at the end. The sharp corners should be filed to avoid the wire feeding tube and current contact nozzle being damaged.
6. Pull out a section of welding wire. Go through the slot and leading wire tube to the welding torch from the rear guide wire. And clamp the wire feed roll.
7. Hold the manual wire feeding on the machine panel, then deliver the welding wire to the torch end. In case of slipping or wire flattening during wire feeding process, please adjust through pressure adjustment bar..

2.5.6 Regulation on Pressure Adjusting Rod

Regulate the black knob of pressure adjusting rod to make the welding wire equally pass through the wire feeding liner and contact nozzle to the end of welding torch. Apply certain resistance to the wire reel after welding wire delivery to prevent wire feed roll slipping. If the pressure bar is adjusted too tight, the welding wire will be flattened, the clad layer on the wire surface will be destroyed, and the service life of feeding roller will be reduced, which will lead more resistance, then worse welding instability. Please adjust the pressing force reasonably.

2.5.7 Air Supply System Connection

Connect the gas pipe to the back panel of the machine, and tighten the hose clamp of gas pipe. Connect the other end to the gas regulator, and tighten the hose clamp, as shown in Fig. 2-6.

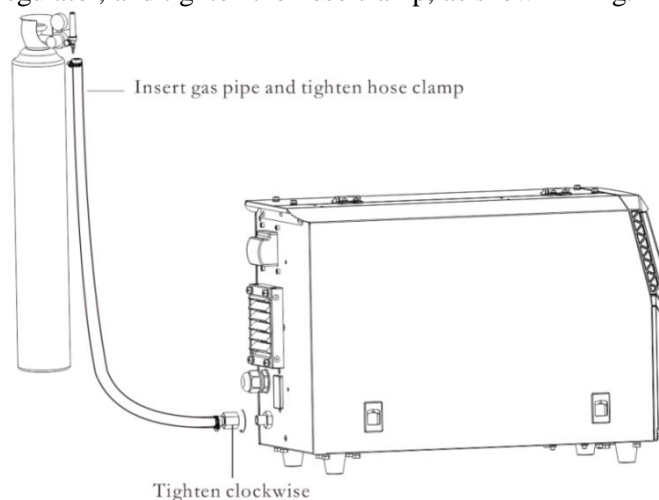

Fig.2- 6 Schematic Diagram of Gas Pipe Connection

📖 Attention:

1. If any protective gas containing CO₂ is used, please use CO₂ heating pressure reducing valve.
2. The gas pipes on welding machine and gas regulator should be firmly fixed; otherwise there will be air leakage.

Chapter III Dex CM3000

Function Description and Operation

3.1 Front Panel

Function description of front panel is as shown in Fig. 3-1.

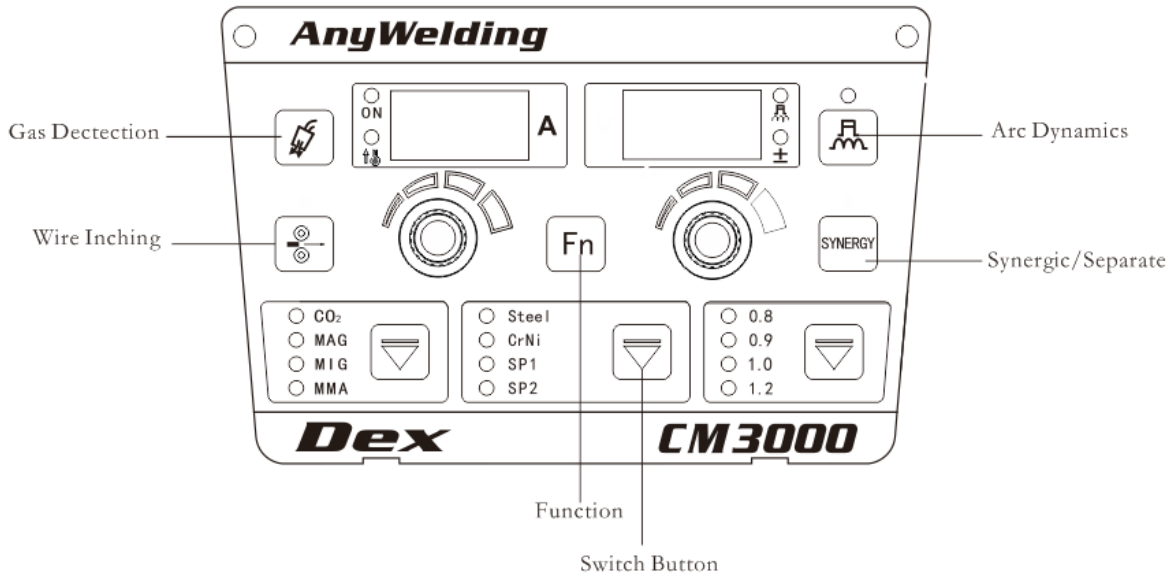

Fig.3- 1 Function Description of Front Panel

3.2 Buttons and Knobs

Button operation is divided into short-press (Touch) and long-press(Hold). Long-press must be hold more than 3 seconds until the system responses.

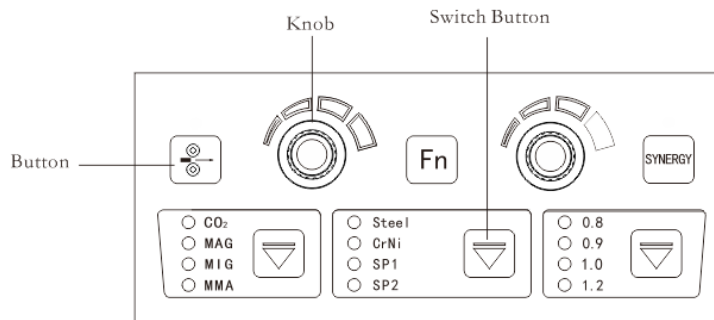

Fig.3- 2 Buttons and Knobs

3.3 Wire Inching

Wire is sent to tip of welding torch by manual under non-welding condition.

Step

1. Press on "Wire Inching" key,the LED light will be on.
The wire inching speed is rated wire feeding speed. The maximum wire inching speed is 8 meters/min.
2. Release the function button;LED light is off, then wire feeding stops.

3.4 Gas Detection



Check whether there is gas or not, and gas flow rate.

Step

1. Touch “Gas Detection” button, LED light will be on.
Gas starts to flow. Then gas flow rate can be checked. Gas detection function will be shut down automatically 30 second later.
2. Press the button again, light LED will be off and gas detection stopped.

3.5 Synergic/Separate

Under the synergic mode, the LED light will last on.

Short-Pressing this button, the right nixie tube will show switch between synergic correction value and synergic voltage

- **Synergic:** Welding voltage varies along with the changes of current. Standard synergic voltage modified value is 0. Voltage modification range is ± 30 .

The rated voltage relationship as below:

The rated welding voltage = the synergic voltage + the voltage modification range (%) \times (the synergic voltage)

- **Separation:** Current & voltage is adjusted separately.

Step

1. Long-pressing "Function" key more than 3 seconds, then enter into internal menu.
2. Turn the left knob and regulate to FC3. (Synergic/Separation Switch)
3. Turn the right knob to switch Synergic or Separation mode. The default value is OFF. (Synergic)

ⓘ Attention

Under the Synergic function, the voltage normal point should be set to zero. Current and voltage matching relationship specified by the manufacturer is realized under normal point.

3.6 Arc Dynamics



Arc dynamics is to adjust hardness of arc.

Harden the arc by adjusting in positive direction and soften arc by negative direction

Arc dynamics are described as shown in Table 3-1 and Fig.3-3.

Table 3-1 Arc Dynamics Description

Arc Dynamics	Functions
0 (Default value)	Universal use, Default value
0~9 (hard arc)	Deep and easy penetrated. Suitable for full position welding and high speed welding. The arc stability also could be ensured under extended cable
0~9 (soft arc)	Shallow and not easy to be fully penetrated. The values are suitable for welding of thin plate.

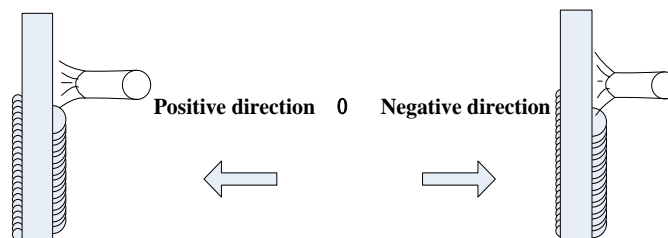



Fig.3-3 Schematic diagram of electric arc dynamics

Step

1. Touch the “Arc Dynamics” button, LED will be on, then arc dynamics function will be on.

2. Under this circumstance, the  LED will be on simultaneously. Rotate the knob to adjust the range of arc dynamics -9~0~+9.

3.7 Internal Menu

Fn The button is to enter into internal menu.

Step

1. Long pressing "Function" key more than 3 seconds to enter into internal menu. Short-Pressing the button to exit the internal menu.
2. Under internal menu settings, turn the left knob and adjust the left nixie tube. Turn the right panel knob and adjust the right nixie tube.
3. Once setting completed, short-press to exit internal menu.

Detailed information of internal menu is as shown in Table 3-2.

Table3- 2 Internal Menu

Function Code	Function Name and Meaning	Adjusting Range	Step Length	Default Value
F01	Restore factory settings			
F10	Slow Wire Feeding Speed	1.4~18m/min.	0.1 m/min.	2.4m/min.
F11	Pre-Gas Time	0~25s	0.1s	0s
F12	Soft-Starting Time	0.001~0.999s	0.001s	Automatic Match
F13	Transition Time of Wire Feeding Speed	0.01~9.99s	0.01s	0.1s
F14	Post-gasTime	0~25s	0.1s	1s
F15	Manual Wire Feeding Speed	1.4~8 m/min.	0.1 m/min.	Automatic Match
F20	DC Burn-Back Voltage	12~30V	0.1V	12V
F21	DC Burn-Back Time	0.00~1.00s	0.01s	Automatic Match
F22	DC Chopping Time	0.00~1.00s	0.01s	0.24s
F23	Fast Rising Slope of DC Welding Short-Circuit Current	1~300	1	Automatic Match
F24	Fast rising Amplitude of DC Welding Short-Circuit Current	0~500A	1A	Automatic Match
F25	Welding control	0~3		OFF (2 steps)
F26	Percentage of wire feeding speed in arc starting stage	1~200		OFF (100)
F27	Synergic voltage corrected value in arc starting stage	-30% ~+30%		0
F28	Arc dynamics in arc starting stage	-9~+9		0
F29	Arc starting time	0~10 seconds		OFF (0)
F50	Arc startingTime	0~10s	0.1s	Temporarily not Open
F51	Arc endingTime	0~10s	0.1s	Temporarily not Open
F52	MMA Arc starting Current	0~400A	1A	300A
F53	MMA Hot-StartingCurrent	0~60A	1A	50A
F54	MMA Thrusting Current	0~50A	1A	30A
F55	DC Welding Energy Control	0~200	1	0
F2A	Percentage of wire feeding speed in arc ending stage	1~200		OFF (100)
F2B	Synergic voltage corrected value in arc ending stage	-30% ~+30%		0
F2C	Arc dynamics in arc ending stage	-9~+9		0
F2D	Arc ending time	0~10seconds		OFF (0)

F2E	Spot welding time	0~10seconds		OFF (0)
FB0	Software Version Query			
FB1	Error Record	0~199		
FB2	Machine Model Query			
FC0	Switch of Rapid Welding Mode/Standard Welding Mode			OFF(Standard Welding Mode)
FC2	MMA Selection Switch			OFF
FC3	Synergic/Separation Switch			OFF (Synergic)

● Slow Wire Feeding Speed (F10)

Check wire-feedingspeedbefore arc starting.

Step

1. Long press "Function" key for more than 3 seconds to enter into internal menu; turn the left knob to F10.
2. Turn right knob to adjust the F10 parameters (shown in table 3-3).
3. Short-press "Function" key to exit internal menu and F10 parameter settings is completed.

Table3- 3Parameter Table of Slow Wire Feeding Speed

Function Code	Unit	Adjusting Range	Step Length	Default Value
F10	m/min.	1.4~18 m/min.	0.1 m/min.	2.4 m/min.

● Pre-Gas Time (F11)

Gas delivery time beforearc starting.

Step

1. Long press "Function" key more than 3 seconds to enter into internal menu, turn the left knob to F11.
2. Turn the right knob to adjust parameters under F11 (shown in table 3-4).
3. Short press "Function" key to exit internal menu, F11 parameter settings is completed.

Table3- 4Parameter Table of Pre-gasTime

Function Code	Unit	Adjusting Range	Step Length	Default Value
F11	s	0~25s	0.1s	0.2s

● Soft-startingTime (F12)

Adjust the time on slow wire feeding or arc starting wire feedingspeed.

Step

1. Long press "Function" key for 3 seconds to enter interior menu, turn the panel knob and adjust the knob to F12.
2. Turn the right knob to adjust F12 parameters(shown in table 3-5)
3. Short press "Function" key to exit from internal menuand F12 parameter settings is completed.

Table3- 5Parameter Table of Hot-start Time

Function Code	Unit	Adjusting Range	Step Length	Default Value
F12	s	0.01~0.999S	0.001S	Automatic Matching

● Transition Time of Wire Feeding Speed (F13)

Transition time from arcing feed wire speed to the given welding wire feeding speed or the transition time from given wire feeding speed to arc ending wire feeding speed.

Step

1. Long press "Function" key for 3 seconds to enter interior menu, turn the left panel knob and adjust the knob to F13.

- Turn the knob on the right panel to adjust F13 parameters (shown in table 3-6).
- Shortpress “Function” key to exit from internal menu and F13 parameter settings is completed.

Table3- 6Parameter Table of Transition Time of Wire Feeding Speed

Function Code	Unit	Adjusting Range	Step Length	Default Value
F13	s	0.01~9.99S	0.01s	0.1s

● **Post-gas Time (F14)**

Post-gas time after arc ending.

Step

- Enter into internalmenu by holding on “Function” key 3 seconds; turn the panel knob to F14.
- Adjust the F14parameters, press“Function” again, F14 parameter settings is completed.

Table3-7Parameter Table of post-gas Time

Function Code	Unit	Adjusting Range	Step Length	Default Value
F14	s	0~25s	0.1s	1s

● **Wire InchingSpeed (F15)**

The speed in which the wire is sent to the tip of the torch under the non-welding condition.

Step

- Enter into internal menu; turn the panel knob to F15. Press “Function” key, then the right LCD will be twinkled.
- Adjust F15 parameters by rotating the right knob (Table 3-8).
- Press “Function”key againto exit from internal menu, F15 parameter settings is completed.

Table3-8 Parameter Table ofManual Wire Feeding Speed

Function Code	Unit	Adjusting Range	Step Length	Default Value
F15	m/min.	1.4~8 m/min.	0.1 m/min.	Automatic Matching

Logicdiagram of DC parameters.

As shown in the figure3-4.

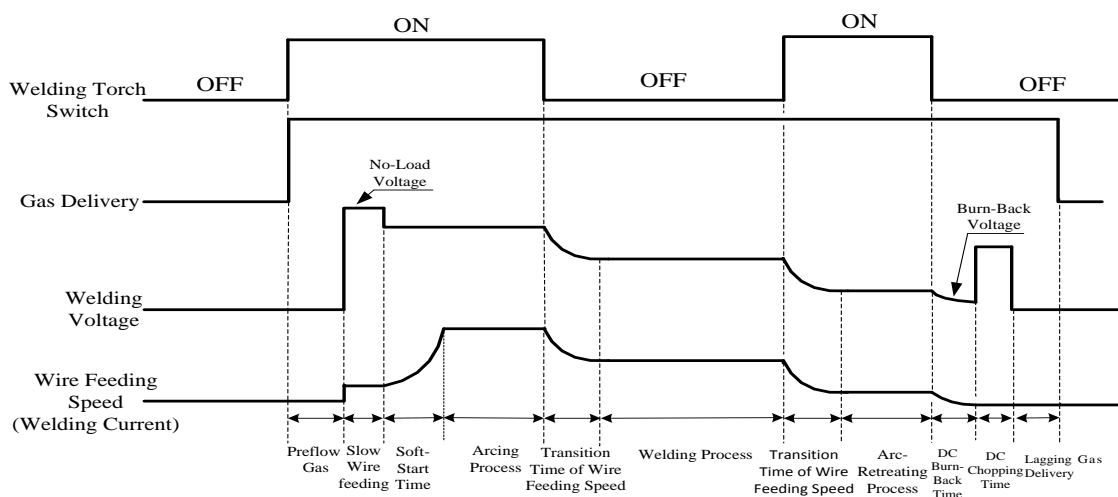

Fig.3-4Logic Diagram of DC Parameters (2T)

● **DC Burn-Back Voltage (F20)**

Step

- Enter into internal menu by long pressing “Function” key; turn the panel knob to F20.

2. Adjust F20 parameters by rotating the right knob (table 3-9)
3. Press “Function” key again to exit from internal menu, F20 parameter settings is completed.

Table3-9ParameterTable of DC Burn-Back Voltage

Function Code	Unit	Adjusting Range	Step Length	Default Value
F20	V	12~30V	0.1V	12V

● DC Burn-Back Time (F21)

Step

1. Enter into internal menu by long pressing “Function” key; turn the panel knob to F21.
2. Adjust F21 parameters by rotating the right knob (table 3-10)
3. Press “Function” key again to exit from internal menu, F21 parameter settings is completed.

Table3-10Parameter Table of DC Burn-Back Time

Function Code	Unit	Adjusting Range	Step Length	Default Value
F21	s	0.00~1.00s	0.01s	Automatic Matching

● DC Chopping Time (F22)

Step

1. Enter into internal menu by long pressing “Function” key; turn the panel knob to F22.
2. Adjust F22 parameters by rotating the right knob (table 3-11)
3. Press “Function” key again to exit from internal menu, F22 parameter settings is completed.

Table3-11Parameter Table of DC Ball-Cleaning Time

Function Code	Unit	Adjusting Range	Step Length	Default Value
F22	s	0.00~1.00s	0.01s	0.24s

● FastRising Slope of DC Welding Short-Circuit Current (F23)

Current rising speed changes during short-circuit time under DC welding status.

Step

1. Enter into internal menu by long pressing “Function” key; turn the panel knob to F23.
2. Adjust F23parameters by rotating the right knob (table 3-12)
3. Press “Function” key again to exit from internal menu, F23parameter settings is completed.

Table3-12 Parameter Table ofQuick Rising Slope of DC Welding Short-Circuit Current

Function Code	Unit	Adjusting Range	Step Length	Default Value
F23	/	1~300	1	Automatic Matching

● FastRising Amplitude of DC Welding Short-Circuit Current (F24)

Current rising speed amplitude during the short-circuit time under DC welding.

Step

1. Enter into internal menu by long pressing “Function” key; turn the panel knob to F24.
2. Adjust F24parameters by rotating the right knob (table 3-13)
3. Press “Function” key again to exit from internal menu, F24 parameter settings is completed.

Table3-13Parameter Table ofQuickRising Amplitude of DC Welding Short-Circuit Current

Function Code	Unit	Adjusting Range	Step Length	Default Value
F24	A	0~500A	1A	AutomaticMatching

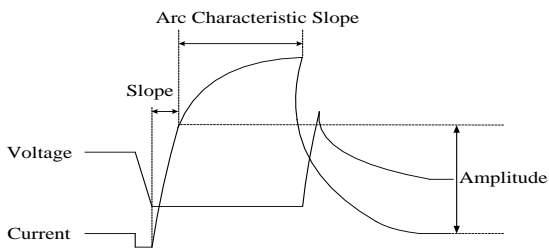

Fig.3-5 Quick Rising Slope and Amplitude of Current

● **Welding Control (F25)**

0 means two steps, 1 means four steps, 2 means special 4 steps, 3 means spot welding. Default value is 0(two steps)

Step

1. Long press "Fn" key more than 3 seconds to enter into internal menu, turn the left knob to F25.
2. Turn the right knob to adjust parameters under F25 (shown in table 3-14).
3. Short press "Fn" key to exit internal menu, F25 parameter settings is completed.

Table3-14 Welding Control Parameter

Function Code	Unit	Adjusting Range	Step Length	Default Value
F25	s	0~3	1	0 (2 Steps)

● **Percentage of wire feeding speed in arc starting stage (F26)**

Step

1. Long press "Fn" key more than 3 seconds to enter into internal menu, turn the left knob to F26.
2. Turn the right knob to adjust parameters under F26 (shown in table 3-15).
3. Short press "Fn" key to exit internal menu, F26 parameter settings is completed.

Table 3-15 Parameters for Percentage of wire feeding speed in arc starting stage

Function Code	Unit	Adjusting Range	Step Length	Default Value
F26	/	1~200	1	100

● **Synergic voltage corrected value in arc starting stage(F27)**

Step

1. Long press "Fn" key more than 3 seconds to enter into internal menu, turn the left knob to F27.
2. Turn the right knob to adjust parameters under F27 (shown in table 3-16).
3. Short press "Fn" key to exit internal menu, F27 parameter settings is completed.

Table3-16 Parameters of Synergic voltage corrected value in arc starting stage

Function Code	Unit	Adjusting Range	Step Length	Default Value
F27		-30~+30	1	0

● **Arc Dynamics in Arc Starting Stage (F28)**

Step

1. Long press "Function" key more than 3 seconds to enter into internal menu, turn the left knob to F28.
2. Turn the right knob to adjust parameters under F28 (shown in table 3-17).
3. Short press "Function" key to exit internal menu, F28 parameter settings is completed.

Table 3-17 Parameters of Arc Dynamics in Arc Starting Stage

Function Code	Unit	Adjusting Range	Step Length	Default Value
F28		-9~+9	1	0

● Arc Starting Time (F29)

Step

1. Long press "Function" key more than 3 seconds to enter into internal menu, turn the left knob to F29.
2. Turn the right knob to adjust parameters under F29 (shown in table 3-18).
3. Short press "Function" key to exit internal menu, F29 parameter settings is completed.

Table 3-18 Parameters of Arc starting

Function Code	Unit	Adjusting Range	Step Length	Default Value
F29		0~10 Seconds	0.1	0

● DC Welding EnergyControl (F55)

Step

1. Enter into internal menu by long pressing "Function" key; turn the panel knob to F55.
2. Adjust F55 parameters by rotating the right knob (table 3-19)
3. Press "Function" key again to exit from internal menu, F55 parameter settings is completed.

Table3- 7Parameter Table of DC Power Control

Function Code	Unit	Adjusting Range	Step Length	Default Value
F55	/	0~200	1	0

Logic diagram of manual welding parameters.

As shown in the figure3-6.

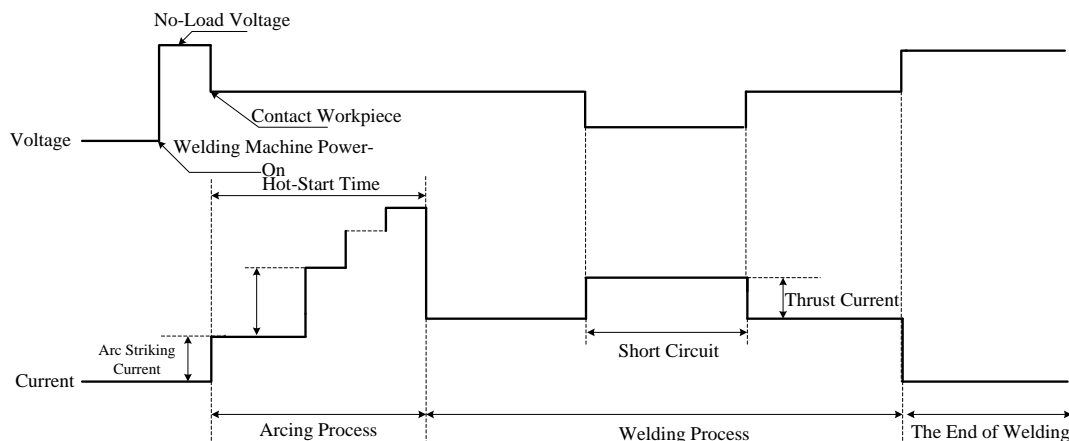

Fig.3- 4 Manual Welding Logic Diagram

● MMA Arc StartingCurrent (F52)

Step

1. Enter into internal menu by long pressing "Function" key; turn the panel knob to F52.
2. Adjust F52 parameters by rotating the right knob (table 3-20)
3. Press "Function" key again to exit from internal menu, F52 parameter settings is completed.

Table3- 20Parameter Table of MMA ArcInitiationCurrent

Function Code	Unit	Adjusting Range	Step Length	Default Value
F52	A	0~400A	1A	300A

● MMA Hot-Starting Current (F53)

Step

1. Enter into internal menu by long pressing "Function" key; turn the panel knob to F53.
2. Adjust F53 parameters by rotating the right knob (table 3-21)
3. Press "Function" key again to exit from internal menu, F53 parameter settings is completed.

Table3- 8Parameter Table of MMA Hot-Starting Current

Function Code	Unit	Adjusting Range	Step Length	Default Value
F53	A	0~60A	1A	50A

- **MMATHrusting Current (F54)**

Step

1. Enter into internal menu by long pressing "Function" key; turn the panel knob to F54.
2. Adjust F54parameters by rotating the right knob (table 3-22)
3. Press "Function" key again to exit from internal menu, F54 parameter settings is completed.

Table3- 22Parameter Table of MMATHrusting Current

Function Code	Unit	Adjusting Range	Step Length	Default Value
F54	A	0~50A	1A	30A

- **Percentage of wire feeding speed in arc ending stage (F2A)**

Step

1. Long press "Fn" key more than 3 seconds to enter into internal menu, turn the left knob to F2A.
2. Turn the right knob to adjust parameters under F2A (shown in table 3-23).
3. Short press "Fn" key to exit internal menu, F2A parameter settings is completed.

Table3-23 Parameters for Percentage of wire feeding speed in arc ending stage

Function Code	Unit	Adjusting Range	Step Length	Default Value
F2A	/	1~200	1	100

- **Synergic voltage corrected value in arc ending stage (F2B)**

Step

1. Long press "Fn" key more than 3 seconds to enter into internal menu, turn the left knob to F2B.
2. Turn the right knob to adjust parameters under F2B (shown in table 3-24).
3. Short press "Fn" key to exit internal menu, F2B parameter settings is completed.

Table3-24 Parameters of Synergic voltage corrected value in arc ending stage

Function Code	Unit	Adjusting Range	Step Length	Default Value
F2B		-30~+30	1	0

- **Arc Dynamics in Arc Ending Stage (F2C)**

Step

1. Long press "Function" key more than 3 seconds to enter into internal menu, turn the left knob to F2C.
2. Turn the right knob to adjust parameters under F2C (shown in table 3-25).
3. Short press "Function" key to exit internal menu, F28Cparameter settings is completed.

Table3-25Parameters of Arc Dynamics in Arc Ending Stage

Function Code	Unit	Adjusting Range	Step Length	Default Value
F2C		-9~+9	1	0

- **Arc Ending Time (F2D)**

Step

1. Long press "Function" key more than 3 seconds to enter into internal menu, turn the left knob to F2D.
2. Turn the right knob to adjust parameters under F2D (shown in table 3-26).
3. Short press "Function" key to exit internal menu, F2D parameter settings is completed.

Table3-26Parameters of Arc Ending

Function Code	Unit	Adjusting Range	Step Length	Default Value
F2D		0~10 Seconds	0.1	0

- **Spot Welding Time (F2E)**

Step

1. Long press "Function" key more than 3 seconds to enter into internal menu, turn the left knob to F2E.
2. Turn the right knob to adjust parameters under F2E (shown in table 3-27).
3. Short press "Function" key to exit internal menu, F2Eparameter settings is completed.

Table3-27 Parameters of Spot welding time

Function Code	Unit	Adjusting Range	Step Length	Default Value
F2E		0~10 Seconds	0.1	0

- **Software VersionQuery (FB0)**

To query software version number.

Step

1. Enter into the internal function, and adjust left panel knob to FB0 (shown in figure 3-7).

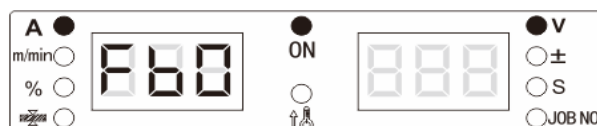

Fig.3- 7FB0 Display Interface

2. Press the "Fn" key, adjust the right panel knob to check software version, as shown in figure 3-8.

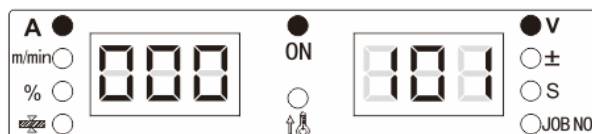

Fig.3- 8 FB0 Display Interface

- **Error Record Query (FB1)**

The error record is total 200 groups. "F00" means power-on self-testing.

Step

1. Enter into internal function, and adjust the left panel knob to FB1 (shown in figure 3-9).
2. Press the "Fn" key, adjust panel right knob to query error record.

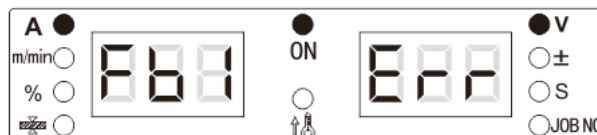

Fig.3- 9 Error Query Display Interface

- **Machine Model Query (FB2)**

Step

1. Enter into internal function, and adjust left panel knob to FB2 (shown in figure3-10).

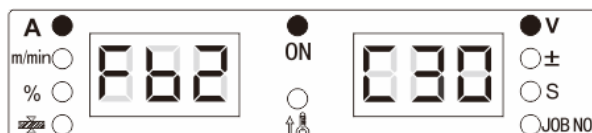

Fig.3-10 Model Query Display Interface

2. Press the "FN" key, nixie tube displays welder model, as shown in figure 3-11.

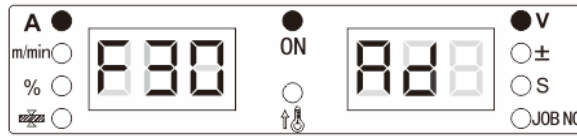

Fig.3- 11 Model Display Interface

● **MMA-Function Switch (FC2)**

Step

1. Enter into internal menu by long pressing “Fn” key; turn the panel knob to FC2.
2. Rotating the right knob to ON and then MMA function will be turned on.
3. Press “Function” key again to exit from internal menu.

● **Swith of Rapid Welding mode / Stardard welding mode (FC0)**

Step

1. Enter into internal menu by long pressing “Function” key; turn left panel knob to FC0.
2. Rotating the right knob to ON and then Quick Welding Function will be turned on.
3. Press “Function” key again to exit from internal menu.

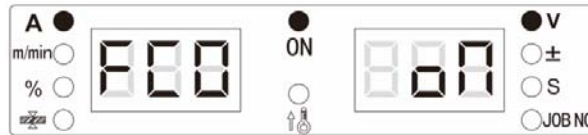

Fig.3- 12 Display Interface

● **Restore Factory Settings (F01)**

Step

1. Enter into internal menu by long pressing “Function” key; turn the panel knob to F01. And nixie tube will be displayed as Fig. 3-13.

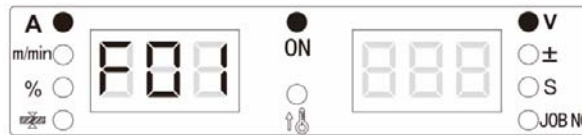

Fig.3-5 Restore Factory Settings Display

2. Long press "Function" key, and the LED display shows "good" and flashing which means successful restoring factory settings (shown in fig.3-14).

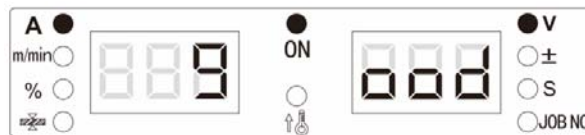

Fig.3-14 "Good" Display Interface

Tips

After restoring factory settings, except the store/recall parameter and locking passwords, all other parameters will be restored to factory settings. Please use this function with care!

Chapter IV Dex PM3000

Function Description and Operation

4.1 FrontPanel

Function description of front panel is as shown in Fig. 4-1.

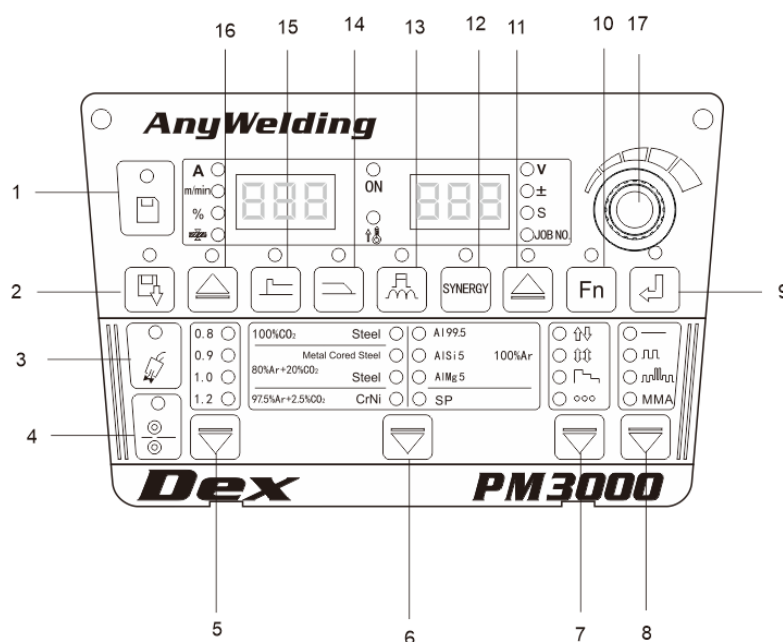



Fig.4-1 Function Description of Front Panel

Table 4-1 Function Description

No.	Number name	Instruction for Each key
1	Storage	Save the selected welding parameters
2	Invocation	Invoke the saved parameters
3	Gas Detection	Check the protective gas
4	Wire Inching	Under non-welding status, the welding wire sent to the end of the welding torch by manual.
5	Wire Diameter	To select different wire diameter
6	Welding Types	To select different welding materials, SP is used for customization on welding material.
7	Welding Control	To select different welding operation mode (2 steps, 4 steps, special 4 steps, spot-welding)
8	Welding Method	To select different welding method (DC, pulse and double pulse welding, switching between different welding rod.)
9	Execution	For parameter confirmation and locking operation.
10	Function	Internal menu parameters setting.
11	Right Rotating Switching Key	Voltage Switch, voltage modification value, time parameter and the channel number.
12	Synergic/Separation	In Synergic mode, the system will match corresponding voltage based on the present current; In separation model, adjust these parameters respectively.
13	Arc Dynamics	Set the arc hardness or Soft
14	Parameter for Arc Ending	To check arc ending current and arc ending voltage, adjustable arc retreating current percentage, arc ending voltage modification value, arc ending time.
15	Parameter for arc starting	To check the arc starting current & voltage, adjustable Percentage of arc ending current, arc starting Voltage Modification Value, arc ending Time and Arc Characteristics.
16	Left Rotating Switching Key	For switching current, wire feeding speed, the percentage and thickness of plates
17	Panel Adjusting Knob	For adjustment of welding parameters, locking parameters and internal menu parameters

4.2 Wire Inching

 Wire is sent to tip of welding torch by manual under non-welding condition.

Step

1. Press on "Wire Inching" key, the LED light will be on.
2. The wire inching speed is rated wire feeding speed. The maximum wire inching speed is 8 meters/min. Release the function button; LED light is off, then wire feeding stops.

4.3 Gas Detection

 Check whether there is gas or not, and gas flow rate.

Step

1. Touch "Gas Detection" button, LED light will be on. Gas starts to flow. Then gas flow rate can be checked. Gas detection function will be shut down automatically 30 second later.
2. Press the button again, light LED will be off and gas detection stopped.

4.4 Synergic /Separation

- **Synergic:** The system will automatically match corresponding voltage based on the set-up giving welding current and synergic voltage corrected value. Standard synergic voltage corrected value is 0. Voltage modification range is ±30.

The rated voltage relationship is as below:

The rated welding voltage = synergic voltage + (voltage modification value%) × (synergic voltage)

Step

1. Pressing " Synergic/separation" button, then enter into synergic mode after LED light turns on.
2. Switch the "Right Rotating Switch" key to synergic voltage corrected value "±".
3. When the indicator light is on or flashing, fine tuning the automatically matched voltage under synergic mode by regulating the voltage knob on wire feeder on front panel, as 4-2 figure shows:
4. The matched value for voltage and arc length corrected value can be viewed by switching "Right Rotating Switch" key.

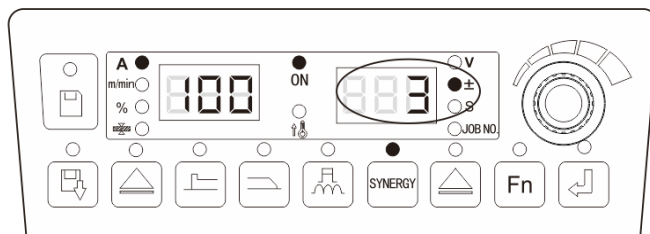

Fig.4- 2 Synergic Mode Matching Voltage Corrected Value Interface

- **Separation:** Current and voltage is adjusted separately.

Step

Long-pressing "Function" key more than 3 seconds. Then enter into "Separation" mode when the LED turns off.

Attention

Parameter for arc starting and ending can be only regulated in "Synergic" mode.

4.5 Arc Dynamics



Arc dynamics is to adjust hardness of arc.

Harden the arc by adjusting in positive direction and soften arc by negative direction

Arc dynamics is described as shown in Table 4-2 and Fig.4-3.

Table 4-2 Arc Dynamics Description

Arc Dynamics	Functions
0 (Default value)	Universal use, Default value
0~9 (hard arc)	Deep and easy penetrated. Suitable for full position welding and high speed welding. The arc stability also could be ensured under extended cable
0~-9 (soft arc)	Shallow and not easy to be fully penetrated. The values are suitable for welding of thin plate.

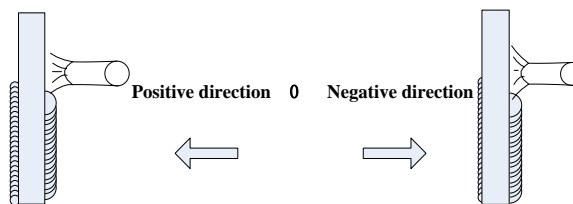

Fig.4-3 Schematic diagram of arc characteristics

Step

1. Touch the "Arc Dynamics" button, LED will be on, then arc dynamics function will be on.
2. Rotate the knob to adjust the range of arc dynamics -9~0~+9.

4.6 Arc Starting Parameter



The parameters involved such as wire feed speed, current, voltage, etc., when welding is started. The relationship of wire starting speed is as follows:

Arc starting feeding speed = current given wire feeding speed × (%) %

Step

1. Pressing the "Arc Starting Parameter" key, arc-starting parameter indicating light and "%" light turns on. Then arc-starting parameter can be set up or viewed.
2. When the "%" indicator is on and the left nixie tube flashes, set up the percentage of wire feeding speed in arc starting status through panel knob. After setting, press "Execute" key to confirm, as shown in Fig.4-4.

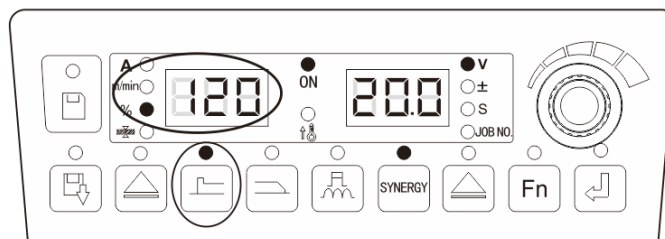

Fig.4-4 Setting Interface of Percentage for Arc Starting Parameter

3. The "±" and "second" of arc starting status can be set up or viewed by "Right Rotating Switch". When the corresponding indicator light is on and the nixie tube flashes, set the corresponding parameters by rotating the panel knob and press "execute" key to confirm.

4. After the parameter for arc starting adjustment is completed, press the key of arc starting parameter key; when the indicator of parameter of arc starting is off, exit the arcing starting parameter setting.
5. Arc starting parameter can be set in 2T, 4 T, and special 4 T.

4.7 Arc Ending Parameter



Parameter for arc ending

During arc welding and welding ending, the involved parameters such as wire feeding speed, current, voltage.

The relation of arc ending wire feeding speed is as follows:

Arc ending Wire Feeding Speed = Given Current Welding Wire Feeding Speed \times (%) %

Step

1. Pressing the "Arc EndingParameter" key, arc-ending parameter indicating light and “%” light turns on. Then arc-ending parameter can be set up or viewed.
2. When the “%” indicator is on and the left nixie tube flashes, set up the percentage of wire feeding speed in arc ending status through panel knob. After setting, press "Execute" key to confirm, as shown in Fig.4-5.

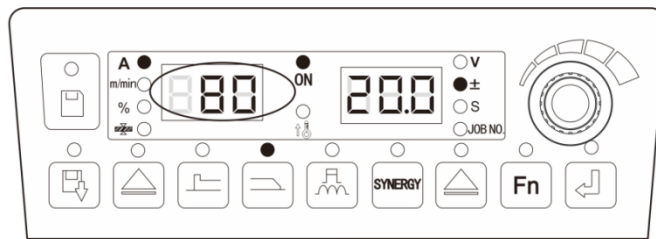

Fig.4-5 Setting Interface of Percentage for Arc Starting Parameter

3. The “±” and “second” of arc starting status can be set up or viewed by “Right Rotating Switch”. When the corresponding indicator light is on and the nixie tube flashes, set the corresponding parameters by rotating the panel knob and press "execute" key to confirm.
4. After the parameter for arc starting adjustment is completed, press the key of arc starting parameter key; when the indicator of parameter of arc starting is off, exit the arcing starting parameter setting. Arc starting parameter can be set in 2T, 4 T, and special 4 T.

Attention

1. The given current in the Parameter for arc retreating can only be adjusted proportionally according to the welding given current and Wire feeding speed and welding current are different characterizations of the same quantity.
2. The given voltage in Parameter for arc ending can only be adjusted in unified model according to the given current.
3. The current of arc retreating and Wire feeding speed can only be viewed while cannot be adjusted.
4. The arc characteristics of the arc ending section and arc characteristics of welding section are independent, and not related.
5. Setting of arc retreating time is decided by the functional logic of 2T, 4 T, special 4T.
6. Parameter for arc retreating which cannot be adjusted on the panel can be adjusted in the internal menu, see 4.10.

4.8 Welding Control

● Spot-welding

Weld the work-piece in the setting spot-welding time Spot-welding function is only controlled by the setting time of the spot-welding, not controlled by the welding torch switch, as shown in Fig. 4-6.

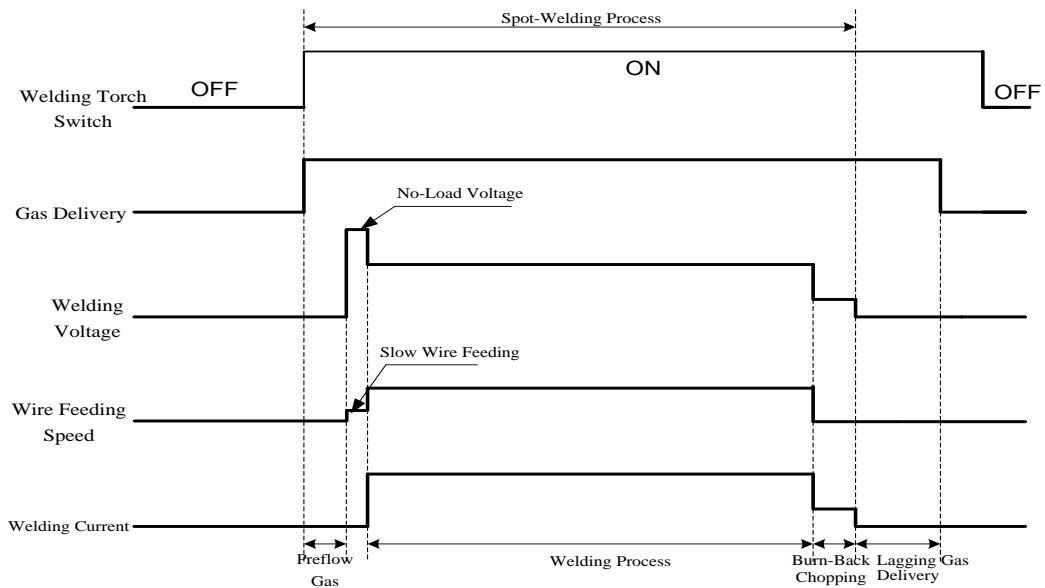

Fig.4- 6 Logic Diagram of Spot-Welding

Step

1. Press the "Welding Control" key, switch to spot-welding mode.
2. Use the "Right Rotating Switch" key to switch to the spot-welding time "second", set the spot welding time (0.1s ~ 10s) with the panel knob, press the "execute" key to confirm, then the spot welding setting is completed.

● 2 T

The logic is shown as figure 4-7

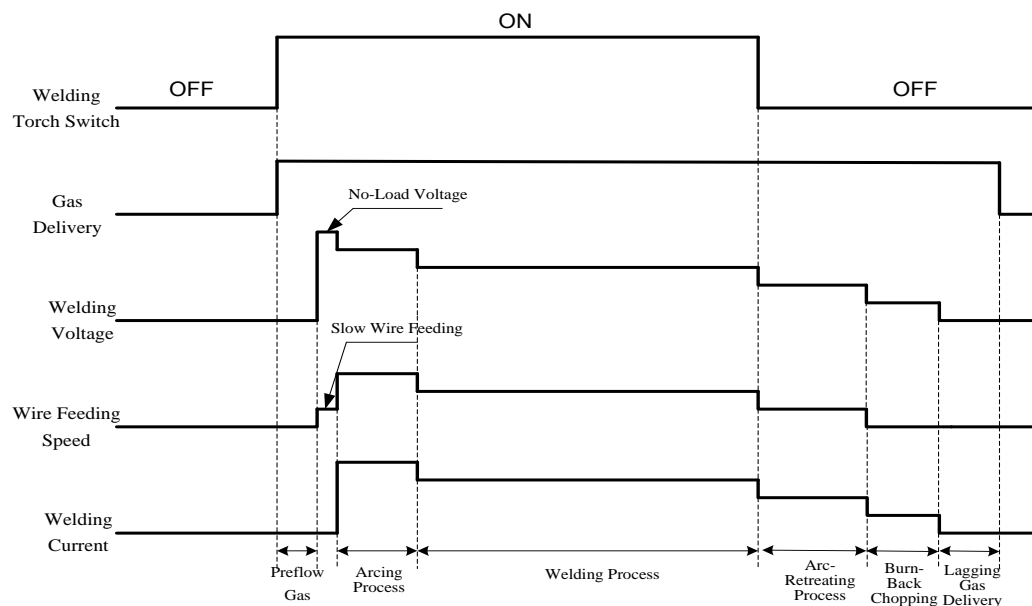

Fig.4- 7 Logic Diagram of 2 T

Attention

Time of parameter for arc starting and parameter for arc ending are determined by the time on the welding power panel.

Step

1. Press the "Welding Control" key, switch to 2T mode.
2. Set parameter for arc starting, and detail can be seen in parameter for arc starting setting.
3. Set parameter for arc ending, and detail can be seen in parameter for arc ending setting.

● **4 T**

The logic is shown as figure 4-8.

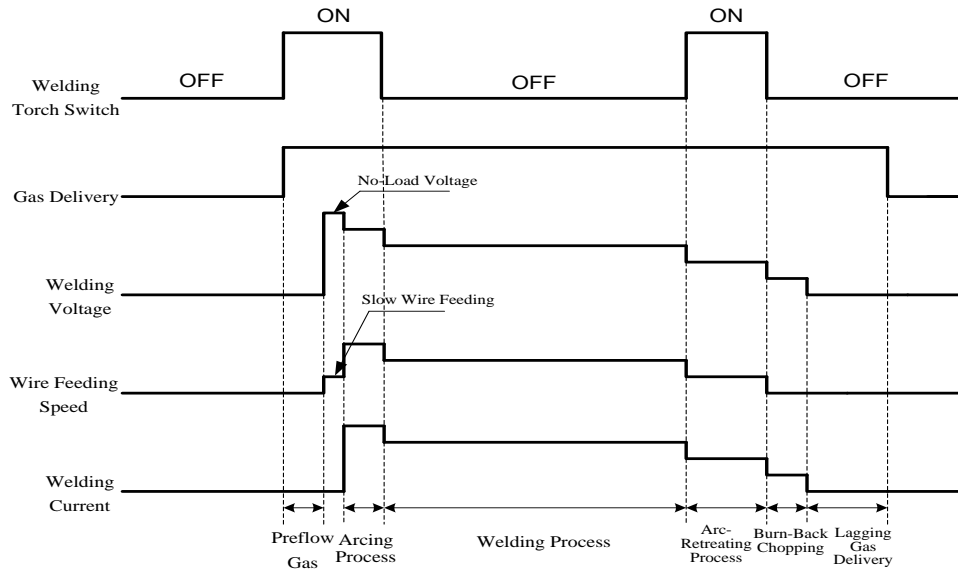

Fig.4- 84T Logic Diagram

Attention:

Arc starting time is determined by arc starting time on welding power source control panel. Arc ending time is determined by time of pressing on welding torch switch.

Step

1. Press the "Welding Control" key, switch to 4Tmode.
2. Set parameter for arc starting, and detail can be seen in parameter for arc starting setting.
3. Set parameter for arc ending, and detail can be seen in parameter for arc ending setting.

● **Special 4 T**

The logic is shown as figure 4-9.

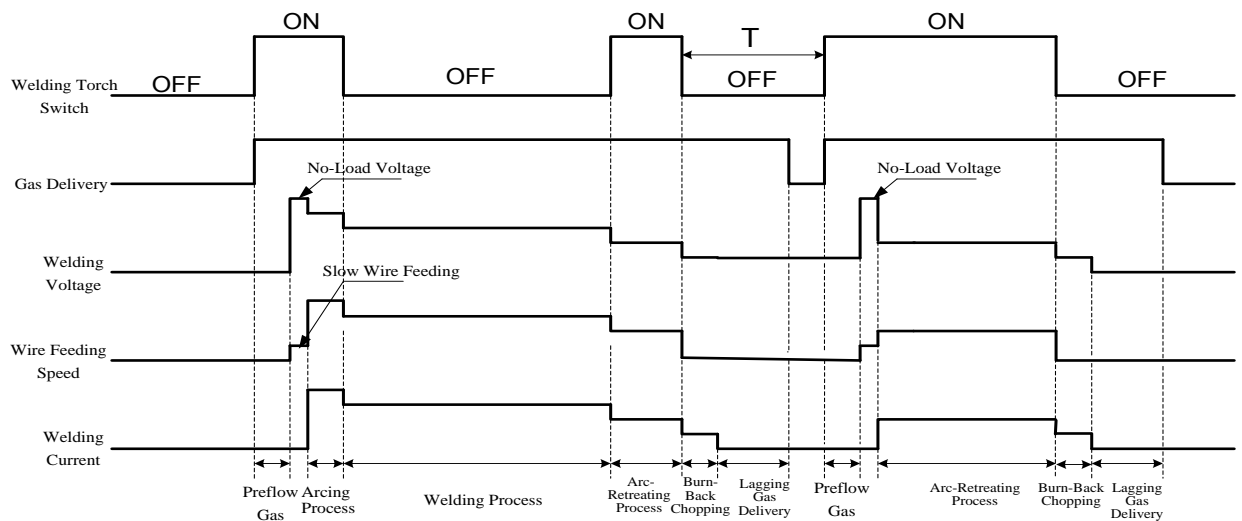

Fig.4-9LogicDiagram of Special 4T

Attention

The Parameter for arc starting time and arc ending time is determined by the time of pressing welding torch switch.

T: If no action after 2 seconds, the repeated arc ending welding finished,

If re-closed the welding torch in 2 seconds, re-enter into arc ending parameter.

Step

1. Press the "Welding Control" key, switch to Special 4T mode.
2. Set parameter for arc starting, and detail can be seen in parameter for arc starting setting.
3. Set parameter for arc ending, and detail can be seen in parameter for arc ending setting.

4.9 Storage and Invocation

● Storage

Store the set welding parameter.

Step

1. Setting welding parameter, press "Storage" key. Storage light will flash and channel light is on, can then select storage channel number.
2. Select channel number with panel knob, press "Execution" key, as shown in fig.4-10.

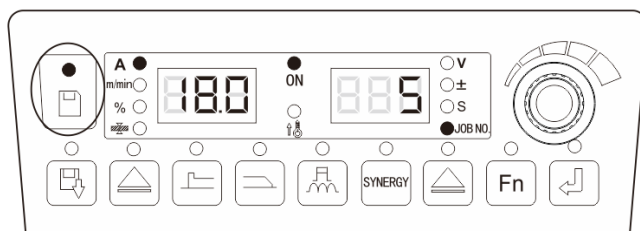

Fig.4-10 Storage Setting Interface

📖 Attention

1. After welding machine to restore factory settings, storage parameter is not clear operation.
2. If not to press "Execution" key to confirm in storing process, parameter will not be save.
3. When storage channel is full, new storage channel number will cover the originals.
4. When storage channel is the same one, new storage channel number will cover the originals.

● Invocation

Invocatethe saved welding parameter.

Step

1. Long press "recall" key, LED light is flashing, and enter parameter invocation mode.
2. Select invocation JOBnumber (0~49) with panel knob, press "Fn" key, as shown in fig.4-11.

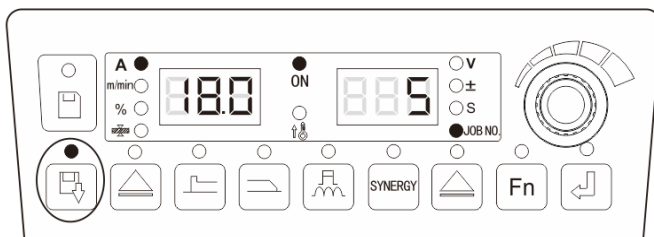

Fig.4-11Invocation Setting Interface

4.10 Internal Menu

Fn

Press "Fn" key to enter into internal menu.

Step

1. Press the "Function" key more than 3 seconds to enter the internal menu settings and the LED will be on. Press "Function" key to exit the internal functions settings, the LED will go out.
2. Enter the internal menu settings, select the parameters, and press the "Execution" key to confirm; When the LED displays "OFF", it would use the default welding power parameters.

Table4-3 Internal Functions

Function Code	Function Name and Meaning	Adjusting Range	Step Length	Default Value
F01	Reset to Factory Settings			
F10	Slow Wire Feeding Speed	1.4~18m/min.	0.1 m/min.	2.4m/min.
F11	Pre-gasTime	0~25s	0.1s	0s
F12	Soft-Start Time	0.001~0.999s	0.001s	Automatic Matching
F13	Transition Time of Wire Feeding Speed	0.01~9.99s	0.01s	0.1s
F14	Post-gas Time	0~25s	0.1s	1s
F15	Wire Inching Speed	1.4~8 m/min.	0.1 m/min.	Automatic Matching
F20	DC Burn-Back Voltage	12~30V	0.1V	12V
F21	DC Burn-Back Time	0.00~1.00s	0.01s	Automatic Matching
F22	DC Chopping Time	0.00~1.00s	0.01s	0.24s
F23	Quick Rising Slope of DC Welding Short-Circuit Current	1~300	1	Automatic Matching
F24	Quick rising Amplitude of DC Welding Short-Circuit Current	0~500A	1A	Automatic Matching
F30	Current Amplitude of Pulse Peak	200~420 A	1A	1250 A
F31	Current Time of Pulse Peak	16~160	1	35
F34	Pulse Burn Back Time	0~1 s	0.01 s	Automatic Matching
F35	Pulse ChoppingTime	0~250	1	53
F40	DoublePulse Frequency	0.2~10	0.1	1
F41	DoublePulse Duty Cycle	1~99	1	50
F42	DoublePulse Intensity	0~50	1	20
F43	CorrectedValue of Weak Pulse Voltage	-30~30	1	0
F44	CorrectedValue of Intense Pulse Voltage	-30~+30	1	0
F52	MMA ArcStrikingCurrent	0~400 A	1A	300A
F53	MMA Hot-StartCurrent	0~60 A	1A	50A
F54	MMA ThrustingCurrent	0~50 A	1A	30A
F55	DC Welding Energy Control	0~200	1	0
FB0	Software Version Query			
FB1	Error Record	0~199		
FB2	Machine Model Query			
FC2	MMA function Switch			OFF

● Slow Wire Feeding Speed (F10)

The speed of wire feeding before arc starting.

Step

1. Enter into internal function, and adjust the panel knob to F10. Press the "Fn" key, and the right nixie tube flashes.
2. Turn the knob on the right panel to adjust the F10 parameters (shown in table 4-4), press the "Fn" key to confirm, and F10 parameter setting is completed.

Table4-4 Parameter Table of Slow Wire Feeding Speed

Function Code	Unit	Adjusting Range	Step Length	Default Value
F10	m/min.	1.4~18 m/min.	0.1 m/min.	1.4 m/min.

● Pre-gasTime (F11)

Gas delivery time before arc starting.

Step

1. Enter into internal function, and adjust the welder panel knob to F11. Press the "Fn" key, and the right nixie tube flashes.
2. Turn the knob on the right panel to adjust the F11 parameters (shown in table 4-5), press the "Fn" key to confirm, and F11 parameter setting is completed.

Table 4-5 Parameter Table of Pre-gas Time

Function Code	Unit	Adjusting Range	Step Length	Default Value
F11	s	0~25 s	0.1 s	0.2 s

● Soft-start Time (F12)

Time from the speed of slow wire feeding to arc wire feeding.

Step

1. Enter into the internal function, and adjust the welder panel knob to F12. Press the "Fn" key, and the right nixie tube flashes.
2. Turn the knob on the right panel to adjust the F12 parameters (shown in table 4-6), press the "Fn" key to confirm, and F12 parameter setting is completed.

Table 4-6 Parameter Table of Hot-start Time

Function Code	Unit	Adjusting Range	Step Length	Default Value
F12	s	0.01~0.999s	0.001s	Automatic Matching

● Transition Time of Wire Feeding Speed (F13)

Time from the arc starting wire speed transition to the given wire feeding speed or the time from the given wire feeding speed transition to the arc ending wire feeding speed.

Step

1. Enter into the internal function, and adjust the welder panel knob to F13. Press the "Fn" key, and the right nixie tube flashes.
2. Turn the knob on the right panel to adjust the F13 parameters (shown in table 4-7), press the "Fn" key to confirm, and F13 parameter setting is completed.

Table 4-7 Parameter Table of Transition Time of Wire Feeding Speed

Function Code	Unit	Adjusting Range	Step Length	Default Value
F13	s	0.01~9.99s	0.01 s	0.1 s

● Post-gasTime (F14)

Post gas time after arc ending.

Step

1. Enter into the internal function, and adjust the welder panel knob to F14. Press the "Fn" key, and the right nixie tube flashes.
2. Turn the knob on the right panel to adjust the F14 parameters (shown in table 4-8), press the "Fn" key to confirm, and F14 parameter setting is completed.

Table 4-8 Parameter Table of Lagging Gas Delivery Time

Function Code	Unit	Adjusting Range	Step Length	Default Value
F14	s	0~25s	0.1s	1s

● Wire Inching Speed (F15)

The wire inching speed under the non-welding condition.

1. Enter into the internal function, and adjust the welder panel knob to F15. Press the "Fn" key, and the right nixie tube flashes.
2. Turn the knob on the right panel to adjust the F15 parameters (shown in table 4-9), press the "Fn" key to confirm, and F15 parameter setting is completed.

Table4-9 Parameter Table of Inching Wire Feeding Speed

Function Code	Unit	Adjusting Range	Step Length	Default Value
F15	m/min.	1.4~8 m/min.	0.1 m/min.	Automatic Matching

Logicdiagram of DC welding parameters.
As shown in the figure4-12.

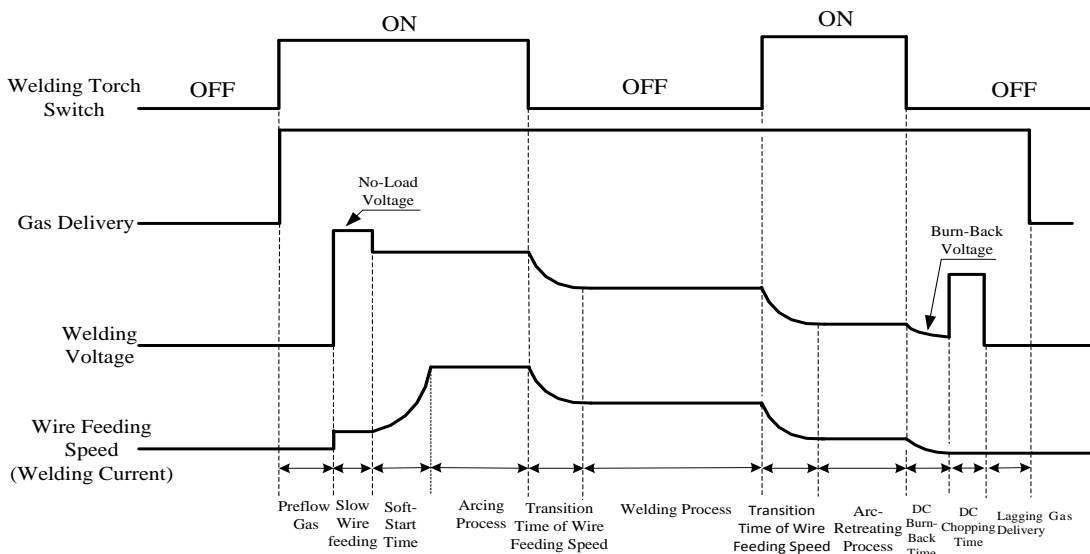

Fig.4-12 Logic Diagram of DC Welding Parameters (4T)

● **DC Burn-Back Voltage (F20)**

Step

1. Enter into the internal function, and adjust the welder panel knob to F20. Press the "Fn" key, and the right nixie tube flashes.
2. Turn the knob on the right panel to adjust the F20 parameters (shown in table 4-10), press the "Fn" key to confirm, and F20 parameter setting is completed.

Table4- 1 Parameter Table of DC Burn-Back Voltage

Function Code	Unit	Adjusting Range	Step Length	Default Value
F20	V	12~30V	0.1V	12V

● **DC Burn-Back Time (F21)**

Step

1. Enter into the internal function, and adjust the welder knob to F21. Press the "Fn" key, and the right nixie tube flashes.
2. Turn the knob on the right panel to adjust the F21 parameters (shown in table 4-11), press the "Fn" key to confirm, and F21 parameter setting is completed.

Table4- 2 Parameter Table of DC Burn-Back Time

Function Code	Unit	Adjusting Range	Step Length	Default Value
F21	s	0.00~1.00s	0.01s	Automatic Matching

● **DC Chopping Time (F22)**

Step

1. Enter into the internal function, and adjust the welder panel knob to F22. Press the "Fn" key, and the right nixie tube flashes.
2. Turn the knob on the right panel to adjust the F22 parameters (shown in table 4-12), press the "Fn" key to confirm, and F22 parameter setting is completed.

Table 4-12 Parameter Table of DC Chopping Time

Function Code	Unit	Adjusting Range	Step Length	Default Value
F22	s	0.00~1.00s	0.01s	0.24s

● Fast Rising Slope of DC Welding Short-Circuit Current (F23)

The current rising speed changes during the short-circuit time under DC welding.

Step

1. Enter into the internal function, and adjust the welder panel knob to F23. Press the "Fn" key, and the right nixie tube flashes.
2. Turn the knob on the right panel to adjust the F23 parameters (shown in table 4-13), press the "Fn" key to confirm, and F23 parameter setting is completed.

Table 4-13 Parameter Table on Fast Rising Slope of DC Welding Short-Circuit Current

Function Code	Unit	Adjusting Range	Step Length	Default Value
F23	/	1~300	1	Automatic Matching

● Quick Rising Amplitude of DC Welding Short-Circuit Current (F24)

The current rising speed amplitude during the short-circuit time when conducting the DC welding.

Step

1. Enter into the internal function, and adjust the welder panel knob to F24. Press the "Fn" key, and the right nixie tube flashes.
2. Turn the knob on the right panel to adjust the F24 parameters (shown in table 4-14), press the "Fn" key to confirm, and F24 parameter setting is completed.

Table 4-14 Parameter Table of Fast Rising Amplitude of DC Welding Short-Circuit Current

Function Code	Unit	Adjusting Range	Step Length	Default Value
F24	A	0~500A	1A	Automatic Match

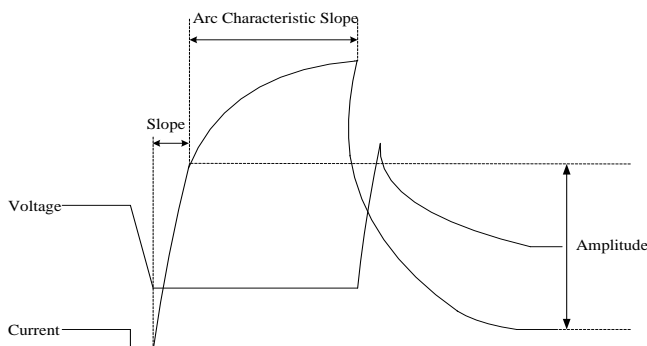

Fig. 4-13 Fast Rising Slope and Amplitude of Current

● DC Welding Energy Control (F55)

Step

1. Enter into the internal function, and adjust the welder panel knob to F55. Press the "Fn" key, and the right nixie tube flashes.
2. Turn the knob on the right panel to adjust the F55 parameters (shown in table 4-15), press the "Fn" key to confirm, and F55 parameter setting is completed.

Table 4-15 Parameter Table of DC Welding Energy Control

Function Code	Unit	Adjusting Range	Step Length	Default Value
F55	/	0~200	1	0

Schematic diagram of pulse and dual pulse parameter.
As shown in the figure4-14.

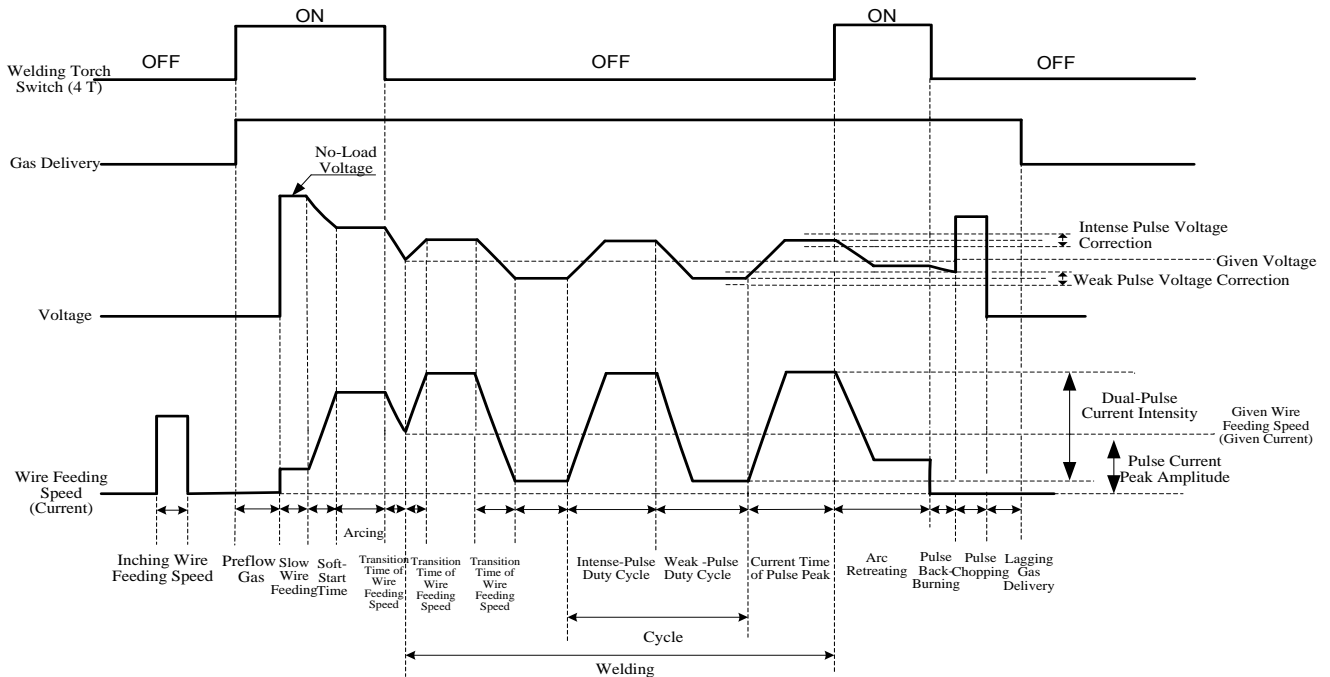

Fig.4-14SchematicDiagram of Pulse and dual Pulse

● **Current Amplitude of PeakPulse (F30)**

Step

1. Enter into the internal function, and adjust the welder panel knob to F30.Press the "Fn" key, and the right nixie tube flashes.
2. Turn the knob on the right panel to adjust the F30 parameters (shown in table 4-16), press the "Fn" key to confirm, and F30 parameter setting is completed.

Table4- 4Parameter Table ofCurrentAmplitude of Pulse Peak

Function Code	Unit	Adjusting Range	Step Length	Default Value
F30	A	200~420A	1A	250A

● **Current Time of PeakPulse (F31)**

Step

1. Enter into the internal function, and adjust the welder panel knob to F31.Press the "Fn" key, and the right nixie tube flashes.
2. Turn the knob on the right panel to adjust the F31 parameters (shown in table 4-17), press the "Fn" key to confirm, and F31 parameter setting is completed.

Table4- 17Parameter Table ofCurrent Time of Pulse Peak

Function Code	Unit	Adjusting Range	Step Length	Default Value
F31	1/32ms	16~160	1	35

● **Pulse Burn-Back Time (F34)**

Step

1. Enter into the internal function, and adjust the welder panel knob to F31. Press the "Fn" key, and the right nixie tube flashes.
2. Turn the knob on the right panel to adjust the F34 parameters (shown in table 4-18), press the "Fn" key to confirm, and F31 parameter setting is completed.

Table 4-18 Parameter Table of Pulse Burn-Back Time

Function Code	Unit	Adjusting Range	Step Length	Default Value
F34	s	0~1s	0.01s	Automatic Matching

● Pulse Chopping Time (F35)

Step

1. Enter into the internal function, and adjust the welder panel knob to F35. Press the "Fn" key, and the right nixie tube flashes.
2. Turn the knob on the right panel to adjust the F35 parameters (shown in table 4-19), press the "Fn" key to confirm, and F35 parameter setting is completed.

Table 4-19 Parameter Table of Pulse Chopping Time

Function Code	Unit	Adjusting Range	Step Length	Default Value
F35	1/32ms	0~250	1	53

● Double Pulse Frequency (F40)

The number of changes that strong pulse and weak pulse within 1 second is called double pulse frequency.

$$f(\text{Frequency}) = \frac{1}{T(\text{Times})}$$

Step

1. Enter into the internal function, and adjust the welder panel knob to F40. Press the "Fn" key, and the right nixie tube flashes.
2. Turn the knob on the right panel to adjust the F40 parameters (shown in table 4-20), press the "Fn" key to confirm, and F40 parameter setting is completed.

Table 4-20 Parameter Table of Double Pulse Frequency

Function Code	Unit	Adjusting Range	Step Length	Default Value
F40	Hz	0.2~10	0.1	1.0

● Double Pulse Duty Cycle (F41)

In one cycle (T), time proportion of the strong pulse and weak pulse

Step

1. Enter into the internal function, and adjust the welder panel knob to F41. Press the "Fn" key, and the right nixie tube flashes.
2. Turn the knob on the right panel to adjust the F41 parameters (shown in table 4-21), press the "Fn" key to confirm, and F41 parameter setting is completed.

Table 4-21 Parameter Table of Double Pulse Duty Cycle

Function Code	Unit	Adjusting Range	Step Length	Default Value
F41	Percentage	0~99	1	50

● Current Intensity of Double Pulse (F42)

Current value during double-pulse welding.

Current calculation formula on double-pulse is as follows:

Set the dual-pulse current parameter value as X

$$\text{Peak current} = 100 + X$$

$$\text{Base current} = 100 - X$$

Step

1. Enter into the internal function, and adjust the welder panel knob to F42. Press the "Fn" key, and the right nixie tube flashes.
2. Turn the knob on the right panel to adjust the F42 parameters (shown in table 4-22), press the "Fn" key to confirm, and F42 parameter setting is completed.

Table4- 22 Parameter Table of Dual Pulse Intensity

Function Code	Unit	Adjusting Range	Step Length	Default Value
F42	Percentage	0~50	1	20

● **Correction Value of Weak Pulse Voltage (F43)**

Correction value of weak pulse voltage during double pulse welding.

Step

1. Enter into the internal function, and adjust the welder panel knob to F43. Press the "Fn" key, and the right nixie tube flashes.
2. Turn the knob on the right panel to adjust the F43 parameters (shown in table 4-23), press the "Fn" key to confirm, and F43 parameter setting is completed.

Table4- 23 Parameter Table of Correction Value of Weak Pulse Voltage

Function Code	Unit	Adjusting Range	Step Length	Default Value
F43	Percentage	-30~30	1	0

● **Correction Value of Intense Pulse Voltage (F44)**

Correction value of intense pulse voltage during double pulse welding.

Step

1. Enter into the internal function, and adjust the welder panel knob to F44. Press the "Fn" key, and the right nixie tube flashes.
2. Turn the knob on the right panel to adjust the F44 parameters (shown in table 4-24), press the "Fn" key to confirm, and F44 parameter setting is completed.

Table4-24 Parameter Table of Correction Value of Intense Pulse Voltage

Function Code	Unit	Adjusting Range	Step Length	Default Value
F44	Percentage	-30~30	1	0

Logic diagram of manual welding parameters.

As shown in the figure4-15.

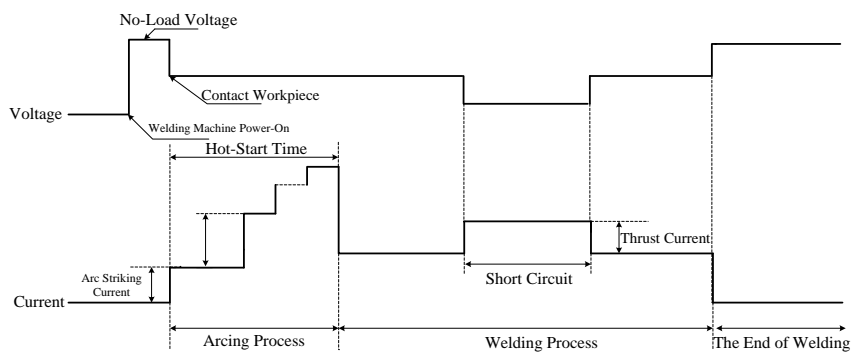

Fig.4- 15 Manual Welding Logic Diagram

● **MMA Arc-striking Current (F52)**

Step

1. Enter into the internal function, and adjust the welder panel knob to F52. Press the "Fn" key, and the right nixie tube flashes.

- Turn the knob on the right panel to adjust the F52 parameters (shown in table 4-25), press the "Fn" key to confirm, and F52 parameter setting is completed.

Table 4-25 Parameter Table of MMA Arc-Starting Current

Function Code	Unit	Adjusting Range	Step Length	Default Value
F52	A	0~400A	1A	300A

● MMA Hot-Starting Current (F53)

Step

- Enter into the internal function, and adjust the welder panel knob to F53. Press the "Fn" key, and the right nixie tube flashes.
- Turn the knob on the right panel to adjust the F53 parameters (shown in table 4-26), press the "Fn" key to confirm, and F53 parameter setting is completed.

Table 4-26 Parameter Table of MMA Hot-Starting Current

Function Code	Unit	Adjusting Range	Step Length	Default Value
F53	A	0~60A	1A	50A

● MMA Thrusting Current (F54)

Step

- Enter into the internal function, and adjust the welder panel knob to F54. Press the "Fn" key, and the right nixie tube flashes.
- Turn the knob on the right panel to adjust the F54 parameters (shown in table 4-27), press the "Fn" key to confirm, and F54 parameter setting is completed.

Table 4-27 Parameter Table of MMA ARC force Current

Function Code	Unit	Adjusting Range	Step Length	Default Value
F54	A	0~50A	1A	30A

● Software Version Query (FB0)

To query software version number.

Step

- Enter into the internal function, and adjust left panel knob to FB0 (shown in figure 4-16).

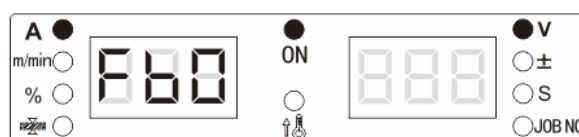

Fig. 4-16 FB0 Display Interface

- Press the "Fn" key, adjust the right panel knob to check software version, as shown in figure 4-17.

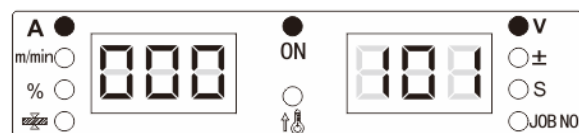

Fig. 4-17 FB0 Display Interface

● Error Record Query (FB1)

The error record is total 200 groups. "F00" means power-on self-testing.

Step

- Enter into internal function, and adjust the left panel knob to FB1 (shown in figure 4-18).

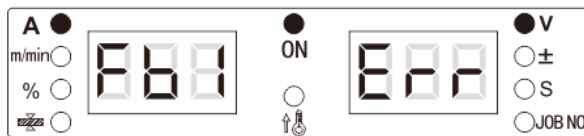

Fig.4-18 Error Query Display Interface

2. Press the "Fn" key, adjust panel right knob to query error record.

● **Machine Model Query (FB2)**

Step

1. Enter into internal function, and adjust left panel knob to FB2 (shown in figure 4-19).

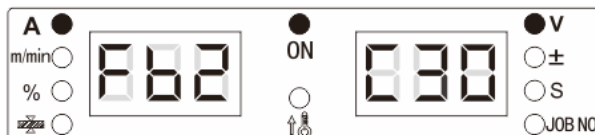

Fig.4-19 Model Query Display Interface

2. Press the "FN" key, nixie tube displays welder model, as shown in figure 4-20.

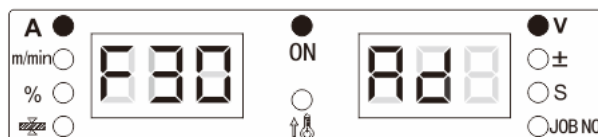

Fig.4-20 Model Display Interface

● **MMA-Function Switch (FC2)**

Step

1. Enter into internal menu by long pressing "Fn" key; turn the panel knob to FC2.
2. Rotating the right knob to ON and then MMA function will be turned on.
3. Press "Function" key again to exit from internal menu.

● **Restore Factory Settings (F01)**

Step

1. Enter into internal menu by long pressing "Function" key; turn the panel knob to F01. And nixie tube will be displayed as Fig. 4-21.



Fig.4-21 Restore Factory Settings Display

2. Long press "Function" key, and the LEDdisplay shows "good" and flashing which means successful restoring factory settings (shown in fig.4-22).



Fig.4-22 "Good" Display Interface

Tips

After restoring factory settings, except the store/recall parameter and locking passwords, all other parameters will be restored to factory settings. Please use this function with care!

Chapter V Troubleshooting

5.1 Welding Machine Fault Indication

In case of any internal fault occurs in the machine, the red indicator light on the welder panel will be on.

Attention

In the process of welding, deviation of current, voltage and setting values are not necessarily caused by a fault, because the difference of gas used, welding wires, dry extension, welding method etc. may also lead to the above phenomenon.

5.2 Fault Codes and Solutions

Fault codes are as shown in figure. 5-1.

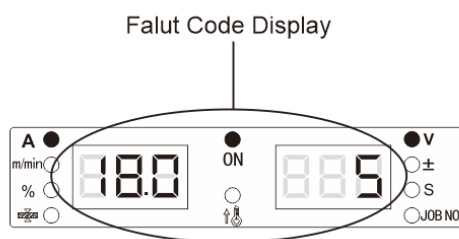

Fig.5-1 Fault Code Display

Welding power fault codes and solutions are as shown in the following table 5-1.

Table 5-1 Welder Fault Reasons and Solutions

Fault Type	Fault Code Display		Fault Description and Reason	Solutions
	Left Nixie Tube	Right Nixie Tube		
Self-Testing once Power-On	F00		/	/
Welding Torch Malfunction	E1		When the welder is switched on, the welding torch switch is turned off or damaged.	Turn the torch switch to OFF state or replace the welding torch switch.
Input Power abnormality	E3	1	Overvoltage of input power cable	1. Check if the input cable is connected properly. 2. Check if the input power supply is normal. 3. M1 panel is damaged. Replace the main power board.
	E3	2	Undervoltage of input power cable	
Over heating	E4	1	Over heating on the output positive terminal: The terminal is seriously hot since the welding torch is not fastened to the European copper head.	Fasten the terminal connector.
	E4	2	Over-temperature of subordinate diode.	1. Strictly follow the rated range of duty cycle. 2. Check the welding power air vent is blocked or not. 3. Clean the dirt from the radiator; 4. Check if the cooling fan works normally.
	E4	3	The primary side radiator is over-temperature.	
* Keypress Error (Dex CM3000)	E5	1~8	The key is stuck.	Check the related buttons are stuck. Please check it ,according to the panel serial number.
* Keypress Error (Dex PM3000)	E5	1~17	The key is stuck.	Please check whether the relevant key is jammed or not, according to the plate number.
Output	E6		1. Output short circuit or the current	1. Check the output is short circuit or not (if the

Fault Type	Fault Code Display		Fault Description and Reason	Solutions
	Left Nixie Tube	Right Nixie Tube		
Overcurrent			is too high. 2. Output diode module is damaged.	nozzles and the contact tip is inadhesion, and if the welding wire is stick to work-piece and occur close short). 2. After inspection, press the welding torch , can go back to work. 3. Check whether the output diode module is damaged.
Communication Fault	E7	1	Internal communication failure.	Check whether the terminals on the display panel and main control board are loosed.
Output Overvoltage	E8		The output voltage is too high. Main transformer damage. Wrong output connection.	1. Check if there are other machines connecting voltage to the output terminals. 2. Check whether the main transformer is damaged. 3. Check the output connection.
PrimarySide Over-Current	E9	11	Main transformer damage. Output diode module damage. Main power board damaged.	1. Check the main transformer; 2. Check the output diode module; 3. Check the main power board; the welder can be restored after the inspection.
	E9	12		
	E9	2		
The Current Hall is not Inserted.	E11		Current hall connector is not inserted.	Check the current hall connector.
Wire Feeder Fault	E13		Overcurrent of wire feed motor	Check whether the welding wire is blocked or jammed.
Fan Failure	E15		Short circuit or open circuit of fan.	Check whether the fan is jammed or in short circuit.
Encoder Failure (DexPM3000)	E17		The signal terminals of the code disc are not firmly connected.	Check whether the signal terminal of the code disc is firmly connected.
Heating Valve Failure	E30		Heating Valve Overcurrent	Check whether the heating valve socket is short circuit.
Motor Power Failure	E33		The power cord of the motor is reversely connected.	Check whether the motor power cord is reversely connected.

 **Attention**

The fault type with the * is only for the model machine in parentheses.

Chapter VI Maintenance

6.1 Daily Inspection

Safety warning

Daily inspection can only be performed after turning off the power of the user distribution box and the machine (Visual inspection which does not require contacting the conductor is excluded) to avoid electric shock, burns and other personal injury accidents.

● Operation Instructions

1. It is of vital importance to keep high performance and safe operation of the welder with daily checking.
2. Conduct daily checks according to the items in the list below. Clean or replace them appropriately.
3. To ensure the high performance of this welder, please select the components provided or recommended by Shenzhen Megmeet Welding Technology Co., Ltd.

● Welding Machine

Table 6- 1 Daily Inspection Contents of Welder

Items	Key points	Remarks
Front Panel	Check whether the mechanical instruments are damaged or loosen. Check whether the cable quick plug connection head is fixed tightly. Observe whether the fault indicator light is shining.	Cable quick plug connection head is a periodic inspection item. In case of any nonconformance, check the internal part of the welder, supplement fastening or replace the components.
Back Panel	Whether the input power cord is loose and broken. Whether the air vent is blocked or not	
Top casing	Check whether the bolts are loosened.	
Bottom Casing	Check whether the casters are damaged or loose (optional)	In case of any nonconformance, supplement fastening or replace the components.
Side Casing	Check whether the side panel is loosened.	
Conventional	Check whether the appearance is discolored or overheat. Check whether the fan's voice is normal during welder operation. Check if there is any odor, abnormal vibration or noise at welding process.	In case of any nonconformance, check the internal part of the welder.

● Cable

Table 6- 2 Daily Inspection Contents of Cable

Items	Key points	Remarks
Ground Cable	Check the ground cable connection	In case of any nonconformance, supplement fastening or replace the components.
Welding Cable	Check whether the insulation layer of the cable is worn or other damaged, and check the bareness of conducting position. Check whether the cable is subject to tension effect of abnormal external force. Check whether the cable is securely connect to the work-piece.	In order to ensure safety and normal welding, appropriate method should be adopted according to the situation of the operation site.

● Other accessories

Table 6- 3 Daily Inspection Contents of Other Accessories

Item	Key points	Remarks
Welding Torch	Routine checks according to the Operation Manual of welding torch.	/
Electric Heating Type CO ₂ Reducing valve	Perform daily checks according to the requirements of the Operation Manual of electric heating type CO ₂ reducing valve	/
Gas Pipe	Check whether the connection is firm, and whether there is any loosening while using a soft clamp. Check whether the flexible hose is worn or damaged.	In case of any nonconformance, supplement fastening or replace the components. Gas pipe replacement.

6.2 Periodic Inspection

Safety Warning

1. To ensure safety, regular checks should be performed by professionals.
2. Regular check can only be performed after turning off the power of the user distribution box and the welder (Visual inspection which does not require contacting the conductor is excluded) to avoid electric shock, burns and other personal injury accidents.
3. Due to the capacitance discharge, checks should be carried out 5 minutes after the welder is powered off.

● Operating Instructions

1. In order to avoid the semiconductor components and circuit board from electrostatic damage, please wear anti-static device before contacting the conductor and circuit board wiring within the machine, or eliminate static electricity via touching the metal part of the casing.
2. Please do not use any solvents other than neutral detergents for household application while cleaning plastic parts.

● Periodic Inspection Plan

1. Periodic inspection must be performed to ensure the long-term and normal use of the equipment.
2. Regular check should be performed in detail, including internal checking and cleaning of the equipment.
3. Generally, regular check is conducted once per every six months. But if the welding spot is dusty, or with heavy oily smoke, regular check internal should be shortened to three months.
4. The recommended periodic checking schedule is as shown in Table6-4.

Table 6- 4PeriodicInspectionSchedule (Year XXXX)

Item No.	Planned inspection date	Actual inspection date	Checked by
1	XXXX		
2	XXXX		
3	XXXX		
...	...		

● Periodic Inspection Contents

(Except for the following items, the user can add inspection items according to the actual situation)

1. Dust Removal within the Welder.

Remove the welder cover and side panel. Dry compressed air can be used to remove the spatter and dust accumulated within the welder. And then clean the dirt and foreign matter which can hardly be removed by purging.

Attention

If too much dust is accumulated on the radiator, heat dissipation will be affected which is prone to causing over-temperature protection.

2. Welding MachineInspection

Remove the top cover and side panel of the welder. Check whether the welder has any peculiar smell, discoloration and over-temperature damage. Check whether the connection part is loosened.

3. Cable and Gas Pipe Checking

Beside daily check, cable, gas pipe, safety ground wire etc. should be further checked in detail and apply routine supplementary fastening. Withstanding voltage test and insulation test Withstanding voltage test and insulation test should be carried out by the after-sales service personnel of our company or personnel with professional knowledge of electrical and welding machine.

Step

1. Turn off the power distribution box.
2. Remove all safety grounding wires on the casing.
3. Connect the three input power cords (not including the yellow green one) to make it short circuit.
4. Turn the welder power switch to "ON".

5. Connect the positive output terminal and negative output terminal with wire on the secondary side to cause short circuit.
6. Connect the pins 3 & 8 of communication connection terminal DB9 with wire on the control side to cause short circuit.
7. Short circuit connection wire used in the above applications should be of the same model. And the sectional area should be no less than 1.25 mm².

📖 Attention

All changes and processing for withstanding voltage test should be restored after the test.

6.3 After-Sales Services

- **Warranty Card**

Each machine is attached with a warranty card. Please fill in the relevant contents on the warranty card. Please read the contents of the warranty card carefully and keep it properly.

- **Maintenance**

The user shall carry out inspection according to the contents of 5.2 Welding power fault codes and solutions, perform initial troubleshooting or record the failure message. Contact your local dealer when you need to repair or replace parts. Please use the components and accessories provided or recommended by Shenzhen MegmeetWelding Technology Co., Ltd.

Two-year warranty is provided by the company. The guarantee time is to be calculated starting from the purchasing time as recorded on the warranty card or invoice.

Product damage due to improper use is not covered by the warranty service. However, it can be handled by repairing.

Annex I Technical Specifications

Annex 1-1 Technical specifications of welding power

Welder	Dex CM3000	Dex PM3000
Control Mode	Digital Control	
Rated Input Voltage/Phase Number	3 Phase AC380V -15%~+21%	
Input Power Supply Frequency	45~65Hz	
Power Factor	0.94	
Efficiency	91% (210A/24.5V)	
Rated Input Capacity	7.8KVA/7.3KW	
Temporary Load Rate	60% @250A/26.5V	
	100% @207A/24.5V	
Output Characteristics	CV	
Rated Output No-Load Voltage	54.2V	
Output Current Range	30A~300A	
Output Voltage Range	12V~30V	
Casing Protection Grade	IP23S	
Wire Feeding Speed	1.4~28 m/min	
Operating Temperature	-10°C~ 40°C(Welding Source- the machine can be started up at 39 °C)	
Storage Temperature	-40°C~ 70°C	
Insulation Level	H	
Size	L*W*H (mm) 610*260*398	
Weight	25.4 Kg	
Wire Coil Diameter	300mm (15kg)	
Certification	CCC (GB/T15579.1-2013) / CE (EN60974-10:2014/EN60974-1:2012)	

Annex II Electrical Connection Diagram

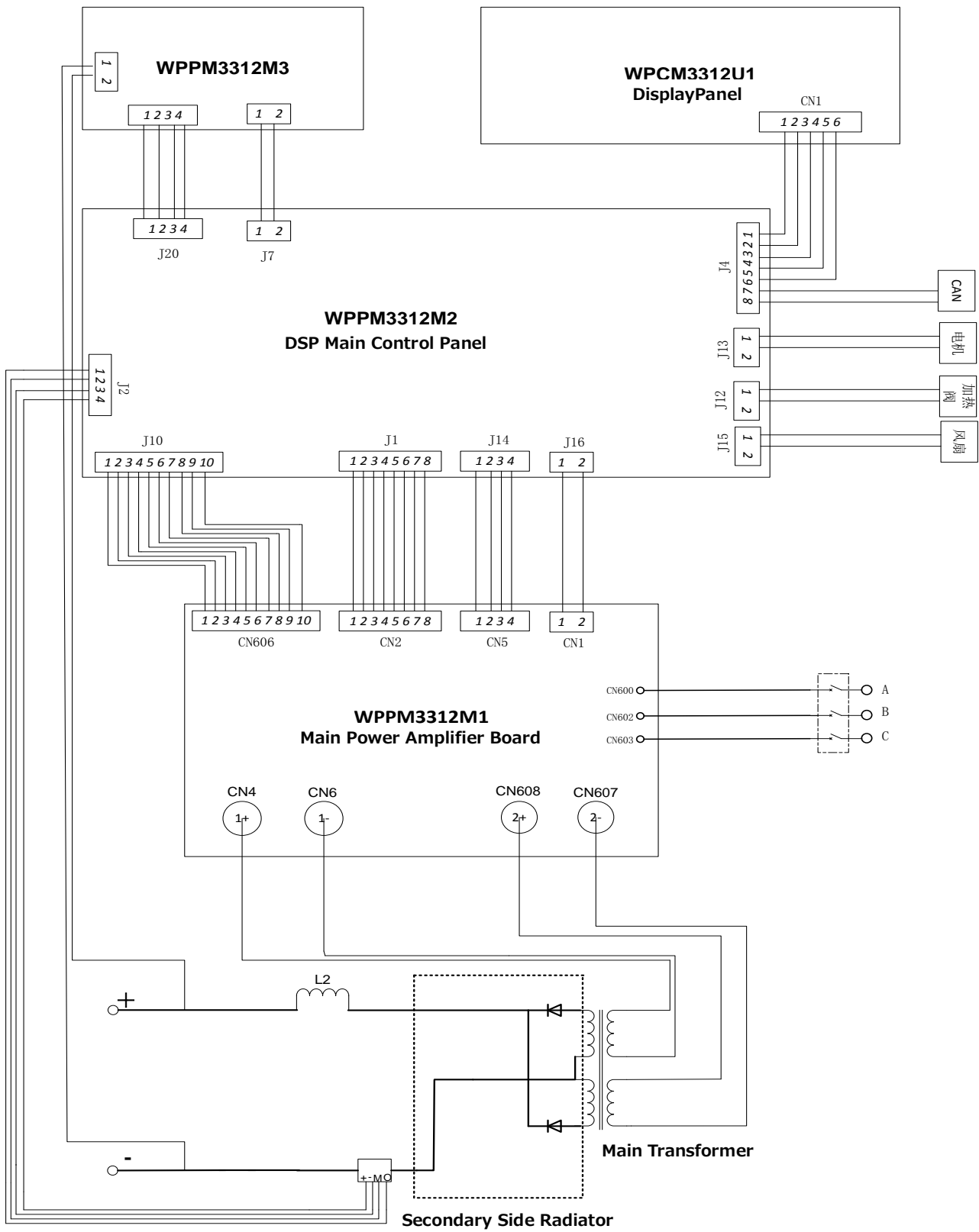

Attached Diagram 2-1 Electrical Connection Diagram of Welder

Annex III System Configuration Table

Dex CM3000Welder Configuration

Attached Table 3-1 Dex CM3000Welder Configuration and Ordering Information

Configuration Name	Model	Configuration	Ordering Code
Welder	Dex CM3000	Standard	R13400620
Ground Cable	25mm ² , 1.8m	Standard	R13500127
Welding Torch	200A/40% Duty Cycle/Japanese Welding Torch and Europe Connector /3M	Standard	R36010164
	150A/60% Duty Cycle/Japanese Welding Torch and Europe Connector /3M	Optional	R36010146
	200A/60% Duty Cycle/Japanese Welding Torch and Europe Connector/3M	Optional	R36010126
Welder wheels	4 pcs/set	Optional	R29140209
CO ₂ HeatingPressure Reducing Valve	Guanghai GH-258	Optional	R34090007
Wire Feed Roller	0.8/1.0 (Contains 2 pcs wire feed roll)	Optional	R29130441
	1.0/1.2 (Contains 2 pcs wire feed roll)	Optional	R29130440
Driving Accessories of Wire Feeding Machine	Motor, Transmission Mechanism, Quick Plug and Wire Feed Roll		R29140271

Attached Table3-2Dex CM3000Process Configuration

Item No.	Welding Materials	Welding Diameter(mm)	Welding Gas	Remarks
1	Solid carbon steel	0.8/0.9/1.0/1.2	100%CO ₂ 80% Ar+20%CO ₂	
2	Solid stainless steel	0.8/0.9/1.0/1.2	97.5% Ar+2.5%CO ₂	
3	Customized			Perform process customization according to customer requirements.
4	Customized			Perform process customization according to customer requirements.

*Notes: Shenzhen MegmeetWelding Technology Co., Ltd. (Megmeet) continues to develop and innovate our product. If the contents, parameters, pictures and objects in the user manual are inconsistent with the actual product, the actual machine shall prevail. We will not make additional notification with respect to the change, and the Company has the final interpretation of the user manual.

Dex PM3000Welder Configuration
Attached Table 3-3DexPM3000Welder Configuration and Ordering Information

Configuration Name	Model	Configuration	Ordering Code
Welder	Dex PM3000	Standard	R13400597
Ground Cable	35mm ² , 1.8m	Standard	R13500137
Welding Torch	250A/35% Duty Cycle/Europe Welding Torch/3M	Standard	R36010430
	300A/40% Duty Cycle/Europe Welding Torch/3M	Optional	R36010059
Welding MachineWheels	4 pcs/set	Optional	R29030709
Accessories Package of Steel Wire Feed Rollers	1.0/1.2mm (Contains 2 pcs wire feed rolls, 2 pcs pressure rolls)	Optional	R29140266
Accessories Package of Steel Wire Feed Rollers	0.8/1.0mm (Contains 2 pcs wire feed rolls, 2 pcs pressure rolls)	Optional	R29140267
Accessories Package of Al Wire Feed Rollers	1.0/1.2mm (Contains 2 pcs wire feed rolls, 2 pcs pressure rolls)	Optional	R29140268
CO ₂ Heating Pressure Reducing Valve	GuanghaiGH-258	Optional	R34090007
Driving Accessories of Wire Feeding Machine	Motor, Transmission Mechanism, Quick Plug and Wire Feed Roll		R29140181

Attached Table3-4DexPM3000Process Configuration

Item No.	Welding Process	Welding Materials	Welding Diameter(mm)	Welding Gas	Remarks
1	DC	Steel	0.8/0.9/1.0/1.2	100% CO ₂	
3			0.8/0.9/1.0/1.2	80% Ar+20% CO ₂	
4			CrNi	0.8/0.9/1.0/1.2	97.5% Ar+2.5% CO ₂
5	Pulse	CrNi	0.8/0.9/1.0/1.2	97.5% Ar+2.5% CO ₂	
6		Al	1.2	100% Ar	
7		AlSi	1.0/1.2		
8		AlMg	1.0/1.2		
9	Double Pulse	CrNi	0.8/0.9/1.0/1.2	97.5% Ar+2.5% CO ₂	
10		Al	1.2	100% Ar	
11		AlSi	1.0/1.2		
12		AlMg	1.0/1.2		

*Notes: Shenzhen Megmeet Welding Technology Co., Ltd. (Megmeet) continues to develop and innovate the product. If the contents, parameters, pictures and objects in the user manual are inconsistent with the actual product, shall prevail. We will not made additional notify with respect to the change, and the Company has the final interpretation of the user manual.

Annex IV Structural Detail Drawing

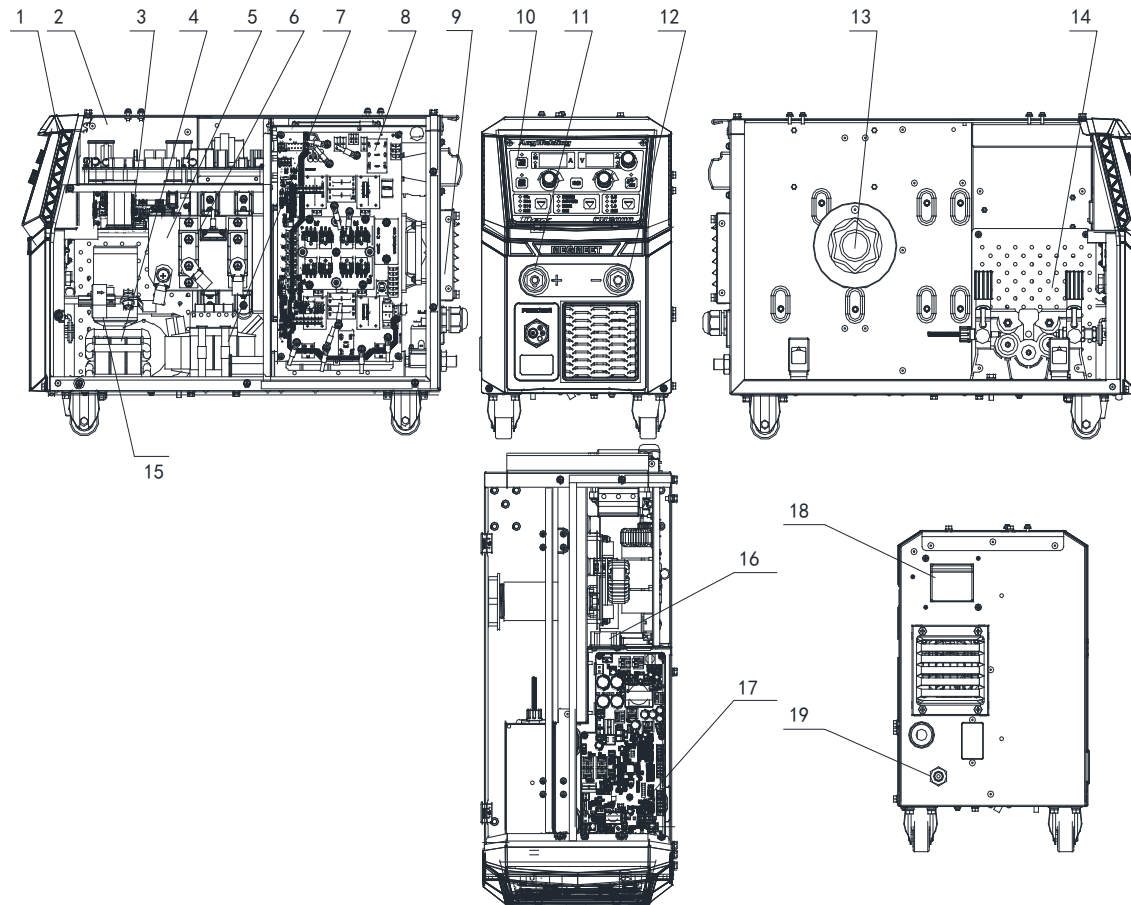

物料名称	订货号	物料编号	订货号
1. Front Plastic Panel	R29060817	11. Output Quick Plug Positive Pole	30042791
2. Case	R29140141	12. Output Quick Plug Negative Pole	30042790
3. Output Current Plate	R11112688	13. Wire Feeding Disc Shaft	R29130363
4. Output Inductance	R22041541	14. Wire Feeding Accessory (with motor)	R29140271 (Dex CM3000)
5. Secondary Side Radiator	R29110196		R29140181 (Dex PM3000)
6. Output Diode	R26020216	15. Current Hall Sensor	R27060045
7. HF Transformer	R23011796	16. Fan in the Machine	R34020064
8. M1 Main Power Amplifier Board	R11112689	17. M2 Main Control Board	R11101148
9. Main Radiating Fan	R34020061	18. Input Air Switch	R34010077
10. Display Board	R11101270 (Dex CM3000)	19. Input Cable	R13500126
	R11101149 (Dex PM3000)		

Attached Fig.4-1DexCM/PM3000Structural Detail Drawing

Welder Warranty Bill

User:	
Detailed Address:	
Postal Code:	Contact Person:
Tel.:	Fax:
Machine model:	
Power:	Machine Number:
Contract Number:	Purchase Date:
Service Unit:	
Contact person:	Tel.:
Repaired By:	Tel.:
Date:	
Customer Evaluation of Service Quality: <input type="checkbox"/> Excellent <input type="checkbox"/> Good <input type="checkbox"/> Moderate <input type="checkbox"/> Poor Others: User Signature: MMDDYY	
Customer Service Center Revisiting Record: <input type="checkbox"/> Telephone Follow-Up <input type="checkbox"/> Letter Follow-Up Others: Signature of Technical Support Engineer:MMDDYY	

Note: This bill is invalid in case of user follow-up visit failure.

Welder Warranty Bill

User:	
Detailed Address:	
Postal Code:	Contact Person:
Tel.:	Fax:
Machine model:	
Power:	Machine Number:
Contract Number:	Purchase Date:
Service Unit:	
Contact person:	Tel.:
Repaired By:	Tel.:
Date:	
Customer Evaluation of Service Quality: <input type="checkbox"/> Excellent <input type="checkbox"/> Good <input type="checkbox"/> Moderate <input type="checkbox"/> Poor Others: User Signature: MMDDYY	
Customer Service Center Revisiting Record: <input type="checkbox"/> Telephone Follow-Up <input type="checkbox"/> Letter Follow-Up Others: Signature of Technical Support Engineer:MMDDYY	

Note: This bill is invalid in case of user follow-up visit failure.

User Instructions

1. Warranty scope covers the body of the welding power supply.
2. The warranty period is 12 months. If any welding power failure or damage occurs during the warranty period when it is used normally, our company provides repair service for free.
3. The warranty period starts from the delivery date of the welding power manufacturing plant. Welding power code is the unique basis for determining the warranty period. The equipment without a welding power code is to be treated as overdue.
4. Even within the warranty period, if the following circumstances occur, certain maintenance fee will be charged:
 - A) Welding power failure caused by not following the User Manual.
 - B) Welding power damage caused by fire, flood, abnormal voltage etc.;
 - c) Welding power damage if the welding power is used for abnormal function.
5. The service charge is calculated according to actual cost. If there is a contract concluded, the contract shall prevail.
6. Please keep this card and show it to the maintenance unit for warranty.
7. If you have any questions, please contact with the agent or contact our company directly.

Customer Service Center of Shenzhen Megmeet Electric Co., Ltd.

Address: Shenzhen Megmeet Welding Technology Co., Ltd. Address: 5F, Block B, Ziguang Information Hub, Langshan Rd., North Nanshan Science and Technology Park, Shenzhen, Guangdong Post code: 518057
After-sales service hotline: 4006662163

User Instructions

1. Warranty scope covers the body of the welding power supply.
2. The warranty period is 12 months. If any welding power failure or damage occurs during the warranty period when it is used normally, our company provides repair service for free.
3. The warranty period starts from the delivery date of the welding power manufacturing plant. Welding power code is the unique basis for determining the warranty period. The equipment without a welding power code is to be treated as overdue.
4. Even within the warranty period, if the following circumstances occur, certain maintenance fee will be charged:
 - A) Welding power failure caused by not following the User Manual.
 - B) Welding power damage caused by fire, flood, abnormal voltage etc.;
 - c) Welding power damage if the welding power is used for abnormal function.
5. The service charge is calculated according to actual cost. If there is a contract concluded, the contract shall prevail.
6. Please keep this card and show it to the maintenance unit for warranty.
7. If you have any questions, please contact with the agent or contact our company directly.

Customer Service Center of Shenzhen Megmeet Electric Co., Ltd.

Address: Shenzhen Megmeet Welding Technology Co., Ltd. Address: 5F, Block B, Ziguang Information Hub, Langshan Rd., North Nanshan Science and Technology Park, Shenzhen, Guangdong Post code: 518057
After-sales service hotline: 4006662163

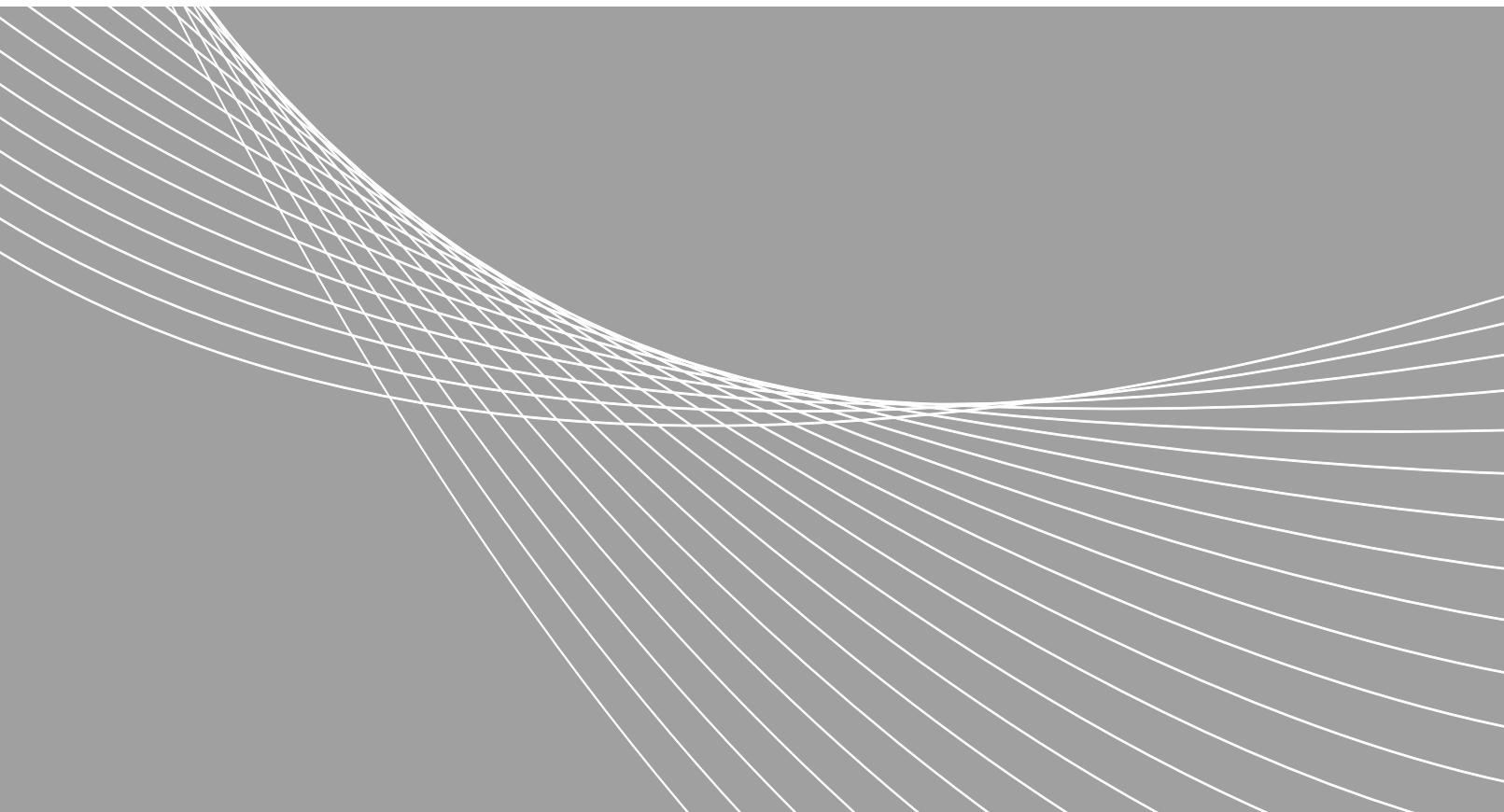

MEGMEET

Shenzhen Megmeet Welding Technology Co., Ltd

5f,Ziguang information Harbor, Langshan Road, Nanshan district, Shenzhen.

www.megmeet.com

weld4s@megmeet.com

Tel:+86-755-86600500

Fax:+86-755-86600840

Postcode:518057

Megmeet will continue devoting to development and innovation of products.
Megmeet reserves the right to modify technical data and product appearance without advance notice.